



Field airborne and impact sound insulation of wood truss floor systems

C. N Himmel and D. J Kupersztoch

JEAcoustics, 1705 West Koenig Lane, Austin, TX 78756, USA

[himmel<at>jeacoustics.com](mailto:himmel@jeacoustics.com)

A series of field measurements on wood truss floors of various types was recently completed at four residential apartment complexes. About 40 floors with different floor finishes, gypsum concrete underlayment, noise control underlayment systems, truss span lengths, ceiling types, and resilient metal channel types were constructed and measured. Trusses were all similar engineered prefabricated parallel chord wood trusses. Room volumes and room absorptive characteristics are varied and non-standard. Measurements are normalized according to ASTM E 1007 and proposed normalized impact sound rating (NISR) procedures to provide a reasonably consistent set for analysis. Low frequency measurements were conducted to 12.5 Hz one-third octave band. For both transmission loss and impact sound, many of the results compare well with predictions using simple regression analysis developed by others using variables such as the mass of the layers, truss depth and spacing, insulation thickness and density, and resilient metal channel spacing.

1 Introduction

Prefabricated parallel chord wood floor trusses, also known as metal plate connected flat wood trusses, are increasing in popularity as an alternative to conventional wood floor joist systems and open web steel joist systems in commercial and residential construction [1, 2]. Flat wood trusses are constructed from small dimensional lumber (minimum size 38 x 89 mm for horizontal chords, and 38 x 64 mm for vertical and diagonal webs) joined by toothed metal plate connectors.

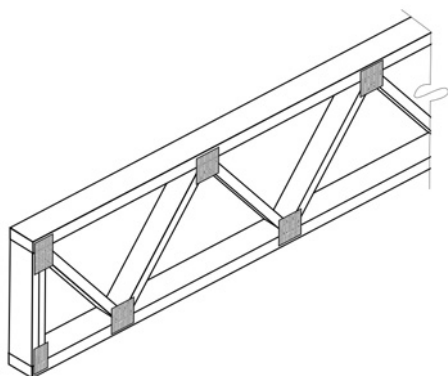

Fig.1 A parallel chord or flat wood truss.

While flat wood trusses are being used increasingly, acoustical data for impact and airborne sound insulation performance of floor-ceiling assemblies that use flat wood trusses is lacking and needs further investigation [3]. Some laboratory test data is available for wood trusses [3, 4] and for similar trusses or open web joists with metal webs and wood chords [5]. More reporting of lab and field test data is needed so that building designers can gauge the compliance of their designs with building code requirements. For example, the International Building Code (IBC) for multifamily dwellings, Sec. 1207 (sound transmission), sets forth minimum airborne and impact ratings when assemblies are laboratory or field tested [6].

The American Society for Testing and Materials (ASTM) standards include test methods for field measurements of the impact sound insulation provided by building elements. Tests involve measuring the sound pressure level in the receiving room below while an impact tapping machine is active on the floor of the source room above.

A number of field acoustical measurements on 457 mm deep flat wood truss floor systems was arranged and completed at newly constructed residential apartment complexes. A total of 43 tests were conducted on various

floor-ceiling assemblies with different floor finishes, gypsum concrete underlayment, noise control underlayment systems, truss span lengths, ceiling types, and resilient metal channel types.

This paper presents normalized field test results in a reasonable consistent set that can hopefully fill a void in available data for use in analysis and design.

2 Field test standard procedures

2.1 Impact noise insulation field tests

Field transmission of impact sound through floors is measured in accordance with ASTM E 1007 [7]. A standardized tapping machine with five steel-faced hammers is placed in various specified positions on the sample floor-ceiling assembly. The hammers are driven by a motor to impact the floor surface at a rate of 10 impacts per second. Sound pressure levels and reverberation decay rates are measured in the receiving room below. The information collected is used to calculate the Impact Sound Pressure Level (L_p), Normalized Impact Sound Pressure Level (L_n), and the Field Impact Insulation Class (FIIC) according to ASTM E 989.

Normalization of impact sound pressure levels is calculated by

$$L_n = L_p - 10 \log(A_0/A_2) \quad (1)$$

where L_p refers to the non-normalized receiving room impact sound pressure level, L_n is the receiving room sound pressure level normalized to a constant room absorption, A_0 , and A_2 is the measured receiving room absorption. The value of A_0 is 10 m^2 or 108 sabins in ASTM E 1007 [8] and ISO 140.

2.2 Airborne noise insulation field tests

ASTM E 336 defines the field test metrics Noise Isolation Class (NIC) and Normalized Noise Isolation Class (NNIC) [9]. NNIC is similar to NIC, except that the measured noise reduction is normalized to a reverberation time of 0.5 s in the receiving room. The standard indicates that 0.5 s is the typical reverberation time when a space is “ordinarily furnished” for occupancy [10], so that NNIC presents what the NIC would be if the receiving room were normally furnished.

Normalization of receiving room sound pressure levels is calculated by

$$L'_n = L'_p - 10 \log(T/T_0) \quad (2)$$

where L'_n is the non-normalized receiving room sound pressure level, L'_p is the receiving room sound pressure level normalized to the reverberation time, T_0 , and T is the reverberation time measured in the receiving room in seconds. The value of T_0 is 0.5 s in ASTM E 336 and ISO 140.

2.3 New metrics for impact test rating

New metrics have been introduced along with proposed modification of the ASTM standards as a solution to limitations in normalizing field impact sound insulation test results [11]. These new metrics are the Impact Sound Rating (ISR) and Normalized Impact Sound Rating (NISR). Instead of using Eq.(1) to normalize impact sound pressure levels, the NISR is calculated by normalization using Eq.(2), similar to NNIC.

3 Tested floor-ceiling samples

The basic floor-ceiling assembly for all samples tested in this effort consists of the following:

- Floor finish (various types, described below)
- 19–32 mm thick self-leveling gypsum concrete
- 2–5 mm resilient noise control floor underlayment system, where used (three types, described below)
- 19 mm thick tongue-and-groove structural plywood or oriented strand board
- 457 mm deep flat wood trusses spaced at 610 mm on center. Truss span lengths varied between 2.9 m and 7.6 m, and trusses were specified to be tied together with perpendicular bracing (or strongbacks) at a maximum spacing of 3 m along span.
- 89–152 mm thick glass fiber batt (GFB) insulation in cavities, tacked to underside of plywood decking under hard floor finishes (not used where floor finish consists of carpet above).
- Resilient metal channels (two types, described below)
- 16 mm type ‘C’ gypsum wallboard (GWB), with one or two layers

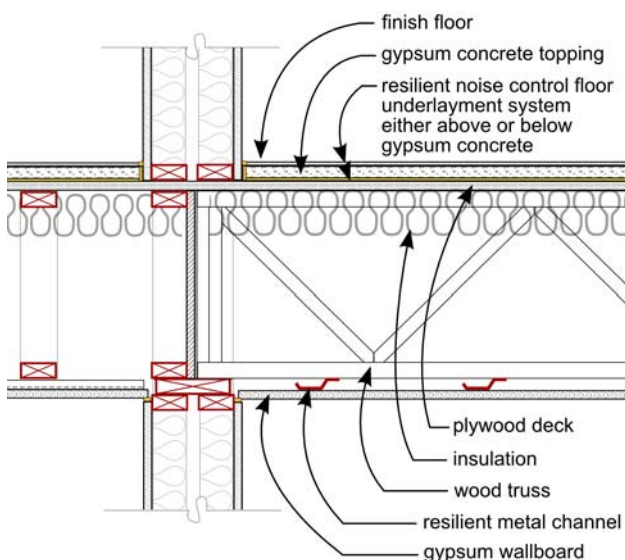

Fig.2 Basic wood truss floor-ceiling assembly with insulation and resilient metal channels.

3.1 Floor finishes

Six types of floor finishes were evaluated: carpet and pad (CPT), vinyl sheet (VSHT), vinyl plank (VPLK), engineered wood laminate (WD), ceramic tile (CER), and slate tile (SLT). In two cases, no floor finishes were installed, and testing was conducted on bare gypsum concrete surfaces.

3.2 Resilient noise control underlayments

Three different resilient noise control floor underlayment systems were evaluated:

Two were different thicknesses of the same type—a recycled rubber mat underlayment (RMU), either 2 mm or 5mm thick, placed above the gypsum concrete topping.

The other type was a resilient composite sheet underlayment (CSU), 5 mm thick, with polyester core of fused entangled filaments attached to a non-woven fabric, placed below the gypsum concrete topping.

3.3 Resilient metal channels

Two types of resilient metal channels were evaluated:

“Standard” resilient metal channels (STD), described to the authors by building contractors as having round holes spaced approximately 50 to 100 mm on center.

“Deluxe” resilient metal channels (DLX), consisting of 25-gauge channel, flange slotted with holes 76 mm by 10 mm wide, spaced 100 mm on center.

Resilient channels are spaced at 406 mm on center, except in two tests, where channels were spaced at 203 mm.

Where resilient metal channels were used, the interface joints of drywall at ceiling and walls were intended to include 6 mm gaps to maintain separation of resiliently mounted ceiling drywall. However, the authors did not observe construction of the tested assemblies, and all drywall joints were taped and floated when testing was conducted. Therefore, it is quite possible that there are rigid connections between drywall panels at walls and ceiling, rather than the intended resilient gaps. It is also possible, but not likely, that 6 mm gaps exist beneath the taped joints.

4 Test procedures

Tests were conducted in general accordance (not strict conformance) with ASTM E 1007 and ASTM E 336. Other exceptions included: no identification and elimination (closure) of flanking paths, no determination of confidence limits, fewer than five samples for linear regression analyses to determine reverberation decay rates, and fewer than four tapping machine positions per test location.

For expediency of field testing, the tapping machine was typically placed in two perpendicular positions, and the other two (diagonal) positions specified by ASTM were not tested. In one of the tests, one position was used, oriented perpendicular to the floor truss, and in five of the tests, all four positions were used.

Measurements were made from 12.5 Hz to 10 kHz.

5 Results

Room Vol. (m ³)	Floor Finish	RMU (mm)	Gyp. Conc. (mm)	CSU (mm)	Floor Deck (mm)	Span (m)	GFB (mm)	RC Type	RC o.c. (mm)	GWB (mm)	ISR	FIIC	NISR	NNIC
109.6	---	---	19	---	19		89	STD	203	16	31	33	32	51
281.7	---	---	19	---	19		89	STD	203	(2) 16	40	---	---	---
65.9	CER	---	19	---	19	2.9	152	STD	406	16	40	44	41	57
166.5	CPT	---	19	---	19	3.7	152	STD	406	16	70	70	71	55
131.7	WD	---	19	---	19	4.8	152	STD	406	16	44	43	44	56
109.8	CPT	---	19	---	19	4.0	152	STD	406	16	73	74	74	53
65.9	CER	---	32	---	19	4.9	89	STD	406	16	36	40	38	53
59.5	CER	---	25	5	19	4.3	89	STD	406	16	49	54	51	58
59.5	CER	---	25	5	19	4.3	89	DLX	406	16	43	48	45	55
65.9	CER	---	25	5	19	4.9	89	STD	406	(2) 16	44	49	47	57
65.9	CER	---	32	---	19	2.9	89	DLX	406	16	37	41	38	55
65.9	CER	---	32	---	19	2.9	89	DLX	406	16	38	41	38	50
73.2	CER	---	25	5	19	5.5	89	DLX	406	(2) 16	47	50	49	58
130.8	CPT	---	32	---	19	3.7	---	STD	406	16	70	71	72	---
130.8	CPT	---	32	---	19	4.1	---	STD	406	16	76	76	77	---
130.8	CPT	---	32	---	19	4.1	---	DLX	406	16	70	69	71	---
130.8	CPT	---	32	---	19	3.7	---	STD	406	(2) 16	73	73	74	---
210.4	VSHT	---	32	---	19	5.8	89	STD	406	16	43	43	45	55
210.4	VSHT	---	25	5	19	4.3	89	STD	406	16	51	50	53	59
210.4	VSHT	---	25	5	19	4.3	89	DLX	406	16	50	49	51	57
210.4	VSHT	---	25	5	19	5.8	89	STD	406	(2) 16	49	48	51	55
263.4	VPLK	---	32	---	19	6.6	89	DLX	406	16	46	44	48	57
263.4	VPLK	---	32	---	19	6.6	89	DLX	406	16	46	45	49	56
201.2	VSHT	---	25	5	19	5.2	89	DLX	406	(2) 16	52	51	53	56
336.6	CPT	---	32	---	19	5.5	---	STD	406	16	73	69	73	55
345.7	CPT	---	32	---	19	6.9	---	STD	406	16	73	70	75	59
345.7	CPT	---	32	---	19	6.9	---	DLX	406	16	72	68	73	55
336.6	CPT	---	32	---	19	5.5	---	STD	406	(2) 16	76	74	79	54
221.3	CPT	---	32	---	19	7.0	---	DLX	406	(2) 16	71	70	73	59
70.0	CER	---	19	---	19	3.0	89	STD	406	16	33	37	35	53
51.2	CER	2	19	---	19	7.6	89	DLX	406	16	40	45	42	57
43.9	CER	2	19	---	19	2.9	89	DLX	406	16	39	44	40	59
57.6	CER	5	19	---	19	2.9	89	DLX	406	16	41	46	43	58
36.6	SLT	---	19	---	19	5.6	89	STD	406	16	40	47	42	---
54.9	SLT	2	19	---	19	7.6	89	DLX	406	16	46	51	48	---
29.3	SLT	5	19	---	19	6.3	89	STD	406	16	49	57	51	---
164.6	VSHT	---	19	---	19	5.5	89	STD	406	16	42	42	44	55
137.2	VPLK	2	19	---	19	7.6	89	DLX	406	16	49	50	51	55
249.7	SLT	2	19	---	19	5.5	89	DLX	406	16	48	46	50	58
137.2	VPLK	2	19	---	19	6.1	89	STD	406	16	44	45	46	50
249.7	SLT	5	19	---	19	5.5	89	DLX	406	16	49	48	51	62
329.3	CPT	---	19	---	19	6.4	---	STD	406	16	68	65	70	55
190.2	CPT	---	19	---	19	4.3	---	DLX	406	16	74	74	76	58

Table 1 Impact and airborne sound insulation results for various floor-ceiling assemblies with 457 mm deep wood trusses

6 Predictive analyses

Results were compared with predictions using simple regression analyses developed by others [12]. The predictive analyses used were developed from laboratory tests and are intended for prediction of ratings of STC and IIC, rather than field performance ratings of NNIC and FIIC. Predictive analyses do not include resilient floor underlayment systems, so no impact insulation comparisons were conducted for floors with resilient underlayment systems. Comparisons were made to investigate differences between field performance results and predicted lab performance estimates.

6.1 With sound absorbing material

IIC and STC performance may be estimated for wood I-joint floor-ceiling assemblies with resilient metal channels and sound absorbing material by

$$STC = 5.6 + 30 \log(M) + .014 d + .016 t_i \quad (3)$$

$$IIC = 29.7 + 7 \log(M) + .01 d + .012 t_i + .094 \rho_i \quad (4)$$

where M is the mass of layers, d is I-joint depth (we use truss depth), t_i is thickness of insulation in the cavity, and ρ_i is density of insulation.

The range in values tested with sound absorbing material is shown in Table 2.

Variable	Values
NISR*	35–53
Predicted IIC*	48–50
NNIC	50–62
Predicted STC	65–72
Trusses	
Depth, mm	457
Spacing, mm	610
Sound absorbing material	
Thickness, mm	89–152
Density, kg/m ³	11.2
Resilient metal channels	
Spacing, mm	203–406
Flooring layers	
Flooring + deck, kg/m ²	53–90
Ceiling, kg/m ²	11–23

Table 2 Estimated maximum and minimum values of parameters used in regression analysis for wood truss floors with resilient metal channels and sound absorbing material, *excluding floors with resilient noise control underlayment systems installed (20 floors)

6.2 Without sound absorbing material

All samples that were tested without sound absorbing material had carpet and pad floor finish. The predictive

analysis, however, is intended for floor-ceilings that have hard floor finishes, not carpet. Therefore, it is not possible to compare predicted and measured impact insulation for the assemblies tested without sound absorbing material. On the other hand, with respect to airborne noise insulation it is possible to compare predicted and measured airborne noise insulation for those assemblies without sound absorbing material. STC performance may be estimated for wood structure floors with hard or carpet finishes, resilient metal channels, and no sound absorbing material by

$$STC = 8.8 + 26.7 \log(M) \quad (5)$$

where M is the mass of layers.

The range in values tested without sound absorbing material is shown in Table 3.

Variable	Values
NNIC	54–59
Predicted STC	55–61
Trusses	
Depth, mm	457
Spacing, mm	610
Resilient metal channels	
Spacing, mm	406
Flooring layers	
Flooring + deck, kg/m ²	56–88
Ceiling, kg/m ²	11–23

Table 3 Estimated maximum and minimum values of parameters used in regression analysis for wood structure floors with resilient metal channels and no sound absorbing material (11 floors)

We should expect predictive analyses for lab performance estimates to exceed measured performance in the field. Bearing this in mind, Table 2 shows good correlation between measured NISR and predicted IIC. Table 3 shows good correlation between measured NNIC and predicted STC. However, in Table 2, there is a pronounced difference between measured NNIC and predicted STC—between 7 and 21 points.

7 Low frequency impact sound levels

Results for low frequency performance could not easily be normalized, because results of reverberation decay measurements appeared to be inconsistent. Therefore, results for non-normalized impact sound levels (L_p) were compared separately for floor-ceiling assemblies with carpet finish, with hard (non-carpet) finish with resilient underlayment systems, and with hard (non-carpet) finish and no resilient underlayment system.

Fig.3 shows that floors with carpet and having relatively shorter span lengths, less than 4.5 m, may tend to allow relatively more low frequency impact noise to emanate at multiple peak frequencies than do spans longer than 4.5 m.

All carpeted floors without absorbing material show a prominent peak at 20 Hz one-third octave band.

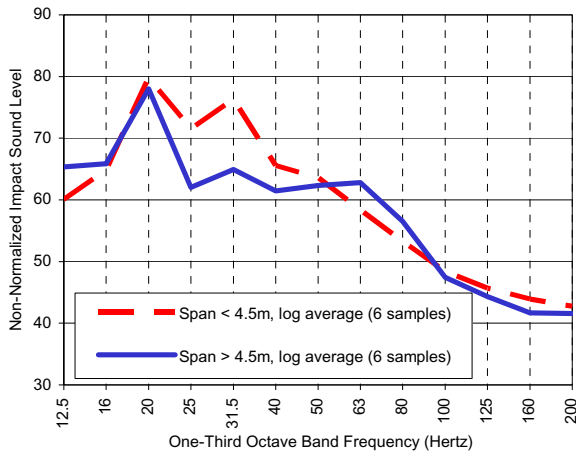

Fig.3 Non-normalized low-frequency impact sound level (L_p) for carpeted wood truss floors without sound absorbing material, for various span lengths.

Fig.4 and Fig.5 show non-normalized low frequency results for floors with hard finishes, sound absorbing material, with and without resilient underlayment systems, and for various spans. Little can be concluded from these comparisons, but it is interesting to note that these results do not share the peaks at 20 Hz (and 31.5 Hz) seen in Fig.3.

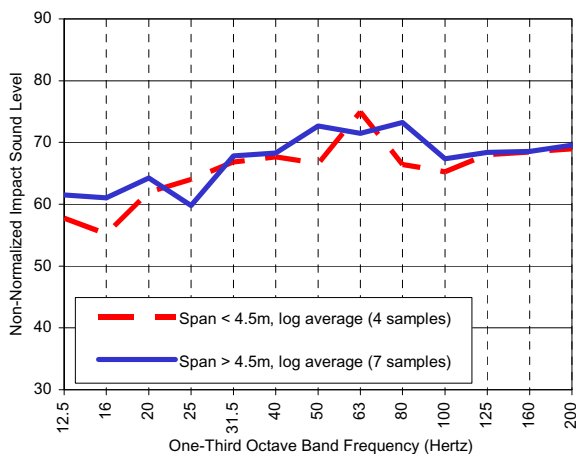

Fig.4 Non-normalized low-frequency impact sound level (L_p) for hard finish floors with sound absorbing material and no resilient floor underlayment systems for various span lengths.

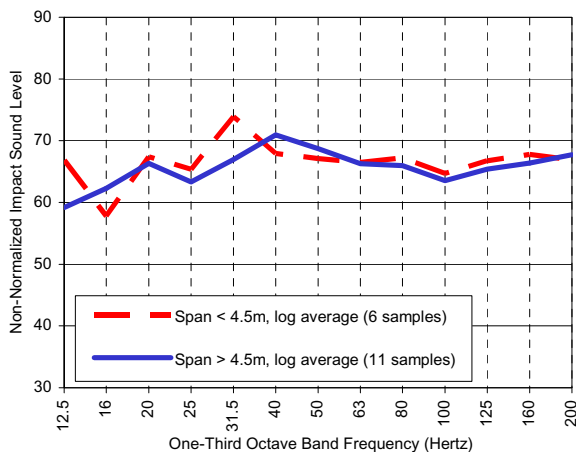

Fig.5 Non-normalized low-frequency impact sound level (L_p) for hard finish floors with sound absorbing material and resilient floor underlayment systems for various spans.

8 Conclusion

This paper presents normalized and non-normalized field test results in a reasonably consistent set that can hopefully fill a void in available data for use in acoustical analysis and design for buildings using wood truss floor systems.

Impact insulation ratings normalized according to proposed NISR methods match reasonably well with predictive analyses.

While the authors expected to find less impact sound insulation associated with longer spans, results did not support that theory. Results do show some surprising evidence that shorter spans with carpet finish or resilient underlayment systems may tend to exhibit less low frequency impact sound insulation. Further investigation is warranted to explore the relationships between span length and impact insulation. Further investigation is also warranted to analyze effects of resilient and rigid connections of ceiling wallboard to walls where resilient metal channels are used.

References

- [1] *Metal Plate Connected Wood Truss Handbook*, Third Edition, Wood Truss Council of Am. (2004).
- [2] K.A. Harman, J.R. Lawson, "A study of metal truss plate connectors when exposed to fire," U.S. Dept of Commerce (2007).
- [3] A.C.C. Warnock, "Sound transmission and impact insulation data," IRC RR-169, National Research Council Canada (2005).
- [4] J.S. Bradley, J.A. Birta, "Laboratory measurements of the sound insulation of building façade elements," IRC IR-818, National Research Council Canada (2000).
- [5] R.B. DuPree, "Catalog of STC and IIC ratings for wall and floor/ceiling assemblies," Office of Noise Control, California Department of Health Services (1981).
- [6] International Building Code 2003, Sec. 1207, Sound Transmission.
- [7] ASTM E 1007-04e1, "Standard test method for field measurement of tapping machine impact sound transmission through floor-ceiling assemblies and associated support structures," ASTM International.
- [8] Reference 6, Sec. 12.1.
- [9] ASTM E 336-05, "Standard test method for measurement of airborne sound attenuation between rooms in buildings," ASTM International.
- [10] Reference 9, Sec. 3.2.6.1 and Sec. 5.4.2.
- [11] J.J. LoVerde, D. W. Dong, "Field impact insulation testing: Inadequacy of existing normalization methods and proposal for new ratings analogous to those for airborne noise reduction," *J. Acoust. Soc. Am.* 118, 638–646 (2005).
- [12] A.C.C. Warnock, J.A. Birta, "Sound transmission class and impact insulation class results," IRC IR-766, National Research Council Canada, (1998).

Appendix

Summary of Test Results

Room	Room Volume	Assembly	Floor Finish	RMU	GCON	CSU	Floor Deck	Truss Span (m)	GFB	RC	RC o.c.	GWB	ISR	FIIC	NISR	NNIC
Lower Room																
Bedroom Unit CV101	109.6	GCON19_PLYWD19_WT457_GFB89_RC(203)_GWB16	---	---	19	---	19	89	STD	203	203	16	31	33	32	51
Living Room Unit CV101	281.7	GCON19_PLYWD19_WT457_GFB89_RC(203)_GWB(2)16	---	---	19	---	19	89	STD	203	203	(2)16	40	44	---	---
Bathroom Unit 2105	65.9	CER_GCON19_PLYWD19_WT457_GFB152.4_RC(406)_GWB16	CER	---	19	---	19	152	STD	406	406	16	40	44	41	57
Bedroom Unit 2105	166.5	CPT_GCON19_PLYWD19_WT457_GFB152.4_RC(406)_GWB16	CPT	---	19	---	19	152	STD	406	406	16	70	70	71	55
Kitchen Unit 2105	131.7	WD_GCON19_PLYWD19_WT457_GFB152.4_RC(406)_GWB16	WD	---	19	---	19	152	STD	406	406	16	44	43	44	56
Living Room Unit 2105	109.8	CPT_GCON19_PLYWD19_WT457_GFB89_RC(406)_GWB16	CPT	---	19	---	19	152	STD	406	406	16	73	74	74	53
Bathroom Unit 1010	65.9	CER_GCON25_CSU5_PLYWD19_WT457_GFB89_RC(406)_GWB16	CER	---	32	---	19	89	STD	406	406	16	36	40	38	53
Bathroom Unit 1012	59.5	CER_GCON25_CSU5_PLYWD19_WT457_GFB89_RC(406)_GWB16	CER	---	25	5	19	4.3	STD	406	406	16	49	54	51	58
Bathroom Unit 1014	59.5	CER_GCON25_CSU5_PLYWD19_WT457_GFB89_RC(406)_GWB16	CER	---	25	5	19	4.3	DLX	406	406	16	43	48	45	55
Bathroom Unit 1016	65.9	CER_GCON25_CSU5_PLYWD19_WT457_GFB89_RC(406)_GWB16	CER	---	25	5	19	4.9	STD	406	406	(2)16	44	49	47	57
Bathroom Unit 1023	65.9	CER_GCON32_PLYWD19_WT457_GFB89_RC(406)_GWB16	CER	---	32	---	19	89	DLX	406	406	16	37	41	38	55
Bathroom Unit 1025	65.9	CER_GCON32_PLYWD19_WT457_GFB89_RC(406)_GWB16	CER	---	32	---	19	89	DLX	406	406	16	38	41	38	50
Bathroom Unit 1027	73.2	CPT_GCON32_PLYWD19_WT457_GFB89_RC(406)_GWB(2)16	CPT	---	32	---	19	5.5	DLX	406	406	(2)16	47	50	49	58
Bedroom Unit 1010	130.8	CPT_GCON32_PLYWD19_WT457_GWB16	CPT	---	32	---	19	3.7	---	406	406	16	70	71	72	---
Bedroom Unit 1012	130.8	CPT_GCON32_PLYWD19_WT457_GWB16	CPT	---	32	---	19	4.1	---	406	406	16	76	76	77	---
Bedroom Unit 1014	130.8	CPT_GCON32_PLYWD19_WT457_GWB16	CPT	---	32	---	19	4.1	---	406	406	16	70	69	71	---
Bedroom Unit 1016	130.8	CPT_GCON32_PLYWD19_WT457_GWB(2)16	CPT	---	32	---	19	3.7	---	406	406	(2)16	73	73	74	---
Kitchen Unit 1010	210.4	VSHT_GCON32_PLYWD19_WT457_GFB89_RC(406)_GWB16	VSHT	---	32	---	19	5.8	STD	406	406	16	43	43	45	55
Kitchen Unit 1012	210.4	VSHT_GCON25_CSU5_PLYWD19_WT457_GFB89_RC(406)_GWB16	VSHT	---	25	5	19	4.3	STD	406	406	16	51	50	53	59
Kitchen Unit 1014	210.4	VSHT_GCON25_CSU5_PLYWD19_WT457_GFB89_RC(406)_GWB16	VSHT	---	25	5	19	4.3	DLX	406	406	16	50	49	51	57
Kitchen Unit 1016	210.4	VSHT_GCON25_CSU5_PLYWD19_WT457_GFB89_RC(406)_GWB(2)16	VSHT	---	25	5	19	5.8	STD	406	406	(2)16	49	48	51	55
Kitchen Unit 1023	263.4	VPLK_GCON32_PLYWD19_WT457_GFB89_RC(406)_GWB16	VPLK	---	32	---	19	6.6	DLX	406	406	16	46	44	48	57
Kitchen Unit 1025	263.4	VPLK_GCON32_PLYWD19_WT457_GFB89_RC(406)_GWB16	VPLK	---	32	---	19	6.6	DLX	406	406	16	46	45	49	56
Kitchen Unit 1027	301.2	VSHT_GCON25_CSU5_PLYWD19_WT457_GFB89_RC(406)_GWB(2)16	VSHT	---	25	5	19	5.2	DLX	406	406	(2)16	52	51	53	56
Living Room Unit 1010	336.6	CPT_GCON32_PLYWD19_WT457_GWB16	CPT	---	32	---	19	5.5	---	406	406	16	73	69	73	55
Living Room Unit 1012	345.7	CPT_GCON32_PLYWD19_WT457_GWB16	CPT	---	32	---	19	6.9	---	406	406	16	73	70	75	59
Living Room Unit 1014	345.7	CPT_GCON32_PLYWD19_WT457_GWB16	CPT	---	32	---	19	6.9	---	406	406	16	72	68	73	55
Living Room Unit 1016	336.6	CPT_GCON32_PLYWD19_WT457_GWB(2)16	CPT	---	32	---	19	5.5	---	406	406	(2)16	76	74	79	54
Living Room Unit 1027	221.3	CPT_GCON32_PLYWD19_WT457_GWB(2)16	CPT	---	32	---	19	7.0	---	406	406	(2)16	71	70	73	59
Bathroom Unit 203	70.0	CER_RMUI2_GCON19_PLYWD19_WT457_GFB89_RC(406)_GWB16	CER	---	19	---	19	89	STD	406	406	16	33	37	35	57
Bathroom Unit 204	51.2	CER_RMUI2_GCON19_PLYWD19_WT457_GFB89_RC(406)_GWB16	CER	2	19	---	19	7.6	DLX	406	406	16	40	45	42	53
Bathroom Unit 205	43.9	CER_RMUI2_GCON19_PLYWD19_WT457_GFB89_RC(406)_GWB16	CER	2	19	---	19	2.9	DLX	406	406	16	39	44	40	59
Bathroom Unit 207	57.6	CER_RMUI5_GCON19_PLYWD19_WT457_GFB89_RC(406)_GWB16	CER	5	19	---	19	2.9	DLX	406	406	16	41	46	43	58
Entry Unit 203	36.6	SLT_GCON19_PLYWD19_WT457_GFB89_RC(406)_GWB16	SLT	---	19	---	19	5.6	STD	406	406	16	40	47	42	---
Entry Unit 204	54.9	SLT_RMUI2_GCON19_PLYWD19_WT457_GFB89_RC(406)_GWB16	SLT	2	19	---	19	7.6	DLX	406	406	16	46	51	48	---
Entry Unit 207	29.3	SLT_RMUI5_GCON19_PLYWD19_WT457_GFB89_RC(406)_GWB16	SLT	5	19	---	19	6.3	STD	406	406	16	49	57	51	---
Kitchen Unit 203	164.6	VSHT_GCON19_PLYWD19_WT457_GFB89_RC(406)_GWB16	VSHT	---	19	---	19	5.5	89	STD	406	16	42	42	44	55
Kitchen Unit 204	137.2	VPLK_RMUI2_GCON19_PLYWD19_WT457_GFB89_RC(406)_GWB16	VPLK	2	19	---	19	7.6	DLX	406	406	16	49	50	51	55
Kitchen Unit 205	249.7	SLT_RMUI2_GCON19_PLYWD19_WT457_GFB89_RC(406)_GWB16	SLT	2	19	---	19	5.5	89	DLX	406	16	48	46	50	58
Kitchen Unit 206	137.2	VPLK_RMUI2_GCON19_PLYWD19_WT457_GFB89_RC(406)_GWB16	VPLK	2	19	---	19	6.1	89	STD	406	16	44	45	46	50
Kitchen Unit 207	249.7	SLT_RMUI5_GCON19_PLYWD19_WT457_GFB89_RC(406)_GWB16	SLT	5	19	---	19	5.5	89	DLX	406	16	49	48	51	62
Living Room Unit 203	329.3	CPT_GCON19_PLYWD19_WT457_GWB16	CPT	---	19	---	19	6.4	---	406	406	16	68	65	70	55
Living Room Unit 204	190.2	CPT_GCON19_PLYWD19_WT457_GWB16	CPT	---	19	---	19	4.3	---	406	406	16	74	74	76	58



Room: Bedroom Unit CV101
Volume: 1078.3 cu.ft. (109.6 cu.m.)
Assembly: GCON19_PLYWD19_WT457_GFB89_RC(203)_GWB16

Test Results:

Frequency (Hz)	L_p (dB)	T_{60} (sec)	L_n^* normalized to $A_0=108$ Sabins (dB)	Deficiencies (dB)	L'_n normalized to $T_0=0.5$ s (dB)
12.5 [†]					
16 [†]					
20 [†]					
25 [†]	67				
31.5 [†]	75				
40 [†]	71				
50 [†]	65				
63 [†]	69				
80 [†]	67	0.7	65		65
100	68	0.6	67	0	67
125	71	0.5	71	0	71
160	70	0.5	70	0	70
200	73	0.6	72	0	72
250	72	0.6	71	0	71
315	71	0.7	70	0	70
400	71	0.8	69	0	69
500	73	0.8	71	0	71
630	74	0.8	72	0	72
800	74	0.7	72	0	73
1000	74	0.6	73	0	73
1250	73	0.7	72	1	72
1600	71	0.7	70	2	70
2000	71	0.7	70	5	70
2500	72	0.7	70	8	71
3150	68	0.7	67	8	67
4000 [†]	63	0.7	62		62
5000 [†]	57	0.7	55		56

ISR = 31

FIIC = 33

NISR = 32

*Measured in general accordance with ASTM E 1007, without determination of confidence limits

[†] One-third octave band not included in FIIC calculations

This page does not constitute a complete report.



Room: Living Room Unit CV101
Volume: 2772 cu.ft. (281.7 cu.m.)
Assembly: GCON19_PLYWD19_WT457_GFB89_RC(203)_GWB(2)16

Test Results:

Frequency (Hz)	L _p (dB)	T ₆₀ (sec)	L _n * normalized to A ₀ =108 Sabins (dB)	Deficiencies L' _n normalized to T ₀ = 0.5 s (dB)
12.5 [†]				
16 [†]				
20 [†]				
25 [†]	58			
31.5 [†]	68			
40 [†]	60			
50 [†]	63			
63 [†]	74			
80 [†]	71	---	---	---
100	67	---	---	---
125	63	---	---	---
160	64	---	---	---
200	67	---	---	---
250	67	---	---	---
315	68	---	---	---
400	68	---	---	---
500	68	---	---	---
630	69	---	---	---
800	68	---	---	---
1000	67	---	---	---
1250	68	---	---	---
1600	65	---	---	---
2000	65	---	---	---
2500	62	---	---	---
3150	59	---	---	---
4000 [†]	54	---	---	---
5000 [†]	47	---	---	---

ISR = 40

FIIC = ---

NISR = ---

*Measured in general accordance with ASTM E 1007, without determination of confidence limits

[†] One-third octave band not included in FIIC calculations

This page does not constitute a complete report.



Room: Bathroom Unit 2105
Volume: 648 cu.ft. (65.9 cu.m.)
Assembly: CER_GCON19_PLYWD19_WT457_GFB152.4_RC(406)_GWB16

Test Results:

Frequency (Hz)	L _p (dB)	T ₆₀ (sec)	L _n * normalized to A ₀ =108 Sabins (dB)	Deficiencies (dB)	L' _n normalized to T ₀ = 0.5 s (dB)
12.5 [†]	63				
16 [†]	60				
20 [†]	61				
25 [†]	56				
31.5 [†]	67				
40 [†]	63				
50 [†]	65				
63 [†]	78				
80 [†]	65	0.4	64		66
100	65	0.4	64	0	66
125	68	0.5	65	0	68
160	72	0.7	68	0	70
200	67	0.7	64	0	66
250	71	0.7	67	0	69
315	71	0.6	68	0	70
400	71	0.6	68	1	70
500	71	0.6	68	2	70
630	71	0.9	66	1	68
800	69	0.9	64	0	67
1000	68	0.8	64	1	66
1250	66	0.9	61	1	64
1600	65	0.9	60	3	63
2000	64	0.6	61	7	63
2500	62	0.6	59	8	61
3150	57	0.7	54	6	56
4000 [†]	51	0.8	47		49
5000 [†]	46	0.8	41		44

ISR = 40

FIIC = 44

NISR = 41

*Measured in general accordance with ASTM E 1007, without determination of confidence limits

[†] One-third octave band not included in FIIC calculations

This page does not constitute a complete report.



Room: Bedroom Unit 2105
Volume: 1638 cu.ft. (166.5 cu.m.)
Assembly: CPT_GCON19_PLYWD19_WT457_GFB152.4_RC(406)_GWB16

Test Results:

Frequency (Hz)	L_p (dB)	T_{60} (sec)	L_n^* normalized to $A_0=108$ Sabins (dB)	Deficiencies (dB)	L'_n normalized to $T_0=0.5$ s (dB)
12.5 [†]	53				
16 [†]	57				
20 [†]	72				
25 [†]	70				
31.5 [†]	82				
40 [†]	67				
50 [†]	66				
63 [†]	59				
80 [†]	50	0.7	50		48
100	50	0.7	50	8	49
125	47	0.7	48	6	46
160	47	0.7	47	5	45
200	43	0.8	43	1	41
250	39	0.6	40	0	38
315	32	0.7	33	0	31
400	27	0.6	28	0	26
500	25	0.6	26	0	24
630	22	0.5	24	0	22
800	21	0.8	21	0	19
1000	21	0.7	22	0	20
1250	20	0.8	20	0	18
1600	19	0.7	19	0	17
2000	18	0.7	19	0	17
2500	18	0.6	19	0	17
3150	18	0.8	17	0	16
4000 [†]	18	0.8	17		16
5000 [†]	18	0.8	18		16

ISR = 70

FIIC = 70

NISR = 71

*Measured in general accordance with ASTM E 1007, without determination of confidence limits

[†] One-third octave band not included in FIIC calculations

This page does not constitute a complete report.



Room: Kitchen Unit 2105
Volume: 1296 cu.ft. (131.7 cu.m.)
Assembly: WD_GCON19_PLYWD19_WT457_GFB152.4_RC(406)_GWB16

Test Results:

Frequency (Hz)	L_p (dB)	T_{60} (sec)	L_n^* normalized to $A_0=108$ Sabins (dB)	Deficiencies (dB)	L'_n normalized to $T_0=0.5$ s (dB)
12.5 [†]	47				
16 [†]	48				
20 [†]	67				
25 [†]	57				
31.5 [†]	64				
40 [†]	63				
50 [†]	68				
63 [†]	74				
80 [†]	77	0.6	77		76
100	73	0.6	73	4	72
125	71	0.3	74	5	73
160	72	0.4	73	4	73
200	71	0.4	73	4	72
250	68	0.5	69	0	68
315	69	0.5	70	1	69
400	67	0.5	68	0	67
500	68	0.8	66	0	66
630	67	0.6	67	1	66
800	64	0.5	65	0	64
1000	61	0.4	62	0	62
1250	60	0.5	61	0	60
1600	57	0.5	57	0	57
2000	57	0.4	59	4	58
2500	55	0.5	56	4	55
3150	49	0.5	50	1	49
4000 [†]	45	0.5	46		45
5000 [†]	39	0.5	40		39

ISR = 44

FIIC = 43

NISR = 44

*Measured in general accordance with ASTM E 1007, without determination of confidence limits

[†] One-third octave band not included in FIIC calculations

This page does not constitute a complete report.



Room: Living Room Unit 2105
Volume: 1080 cu.ft. (109.8 cu.m.)
Assembly: CPT_GCON19_PLYWD19_WT457_GFB152.4_RC(406)_GWB16

Test Results:

Frequency (Hz)	L _p (dB)	T ₆₀ (sec)	L _n * normalized to A ₀ =108 Sabins (dB)	Deficiencies (dB)	L' _n normalized to T ₀ = 0.5 s (dB)
12.5 [†]	50				
16 [†]	56				
20 [†]	72				
25 [†]	74				
31.5 [†]	76				
40 [†]	61				
50 [†]	56				
63 [†]	59				
80 [†]	58	0.6	57		57
100	47	0.6	46	8	46
125	42	0.6	41	3	41
160	43	0.5	43	5	43
200	39	0.7	37	0	37
250	36	0.6	35	0	35
315	32	0.6	31	0	31
400	29	0.7	27	0	27
500	25	0.7	24	0	24
630	21	0.5	21	0	21
800	22	0.7	20	0	20
1000	22	0.6	21	0	21
1250	21	0.6	20	0	20
1600	20	0.6	19	0	19
2000	20	0.5	20	0	20
2500	20	0.6	19	0	19
3150	19	0.7	17	0	17
4000 [†]	18	0.6	17		17
5000 [†]	18	0.6	17		17

ISR = 73

FIIC = 74

NISR = 74

*Measured in general accordance with ASTM E 1007, without determination of confidence limits

[†] One-third octave band not included in FIIC calculations

This page does not constitute a complete report.



Room: Bathroom Unit 1010
Volume: 648 cu.ft. (65.9 cu.m.)
Assembly: CER_GCON32_PLYWD19_WT457_GFB89_RC(406)_GWB16

Test Results:

Frequency (Hz)	L_p (dB)	T_{60} (sec)	L_n^* normalized to $A_0=108$ Sabins (dB)	Deficiencies L'_n normalized to (dB)	L'_n normalized to $T_0=0.5$ s (dB)
12.5 [†]	43				
16 [†]	54				
20 [†]	65				
25 [†]	63				
31.5 [†]	70				
40 [†]	67				
50 [†]	67				
63 [†]	68				
80 [†]	67	0.6	64		67
100	62	0.6	58	0	61
125	69	0.6	66	0	68
160	70	0.6	67	0	69
200	74	0.6	71	0	73
250	73	0.8	69	0	71
315	72	0.9	67	0	70
400	72	1.1	66	0	68
500	71	1.0	66	0	68
630	72	0.9	68	0	70
800	73	1.0	67	0	70
1000	70	1.1	65	0	67
1250	69	0.9	65	1	67
1600	68	0.9	63	2	65
2000	69	0.7	65	7	67
2500	67	0.7	63	8	65
3150	62	0.7	59	7	61
4000 [†]	56	0.7	52		54
5000 [†]	46	0.7	42		44

ISR = 36

FIIC = 40

NISR = 38

*Measured in general accordance with ASTM E 1007, without determination of confidence limits

[†] One-third octave band not included in FIIC calculations

This page does not constitute a complete report.



Room: Bathroom Unit 1012
Volume: 585 cu.ft. (59.5 cu.m.)
Assembly: CER_GCON25_CSU5_PLYWD19_WT457_GFB89_RC(406)_GWB16

Test Results:

Frequency (Hz)	L_p (dB)	T_{60} (sec)	L_n^* normalized to $A_0=108$ Sabins (dB)	Deficiencies (dB)	L'_n normalized to $T_0=0.5$ s (dB)
12.5 [†]	49				
16 [†]	52				
20 [†]	61				
25 [†]	68				
31.5 [†]	67				
40 [†]	62				
50 [†]	66				
63 [†]	63				
80 [†]	63	0.6	59		62
100	62	0.6	59	1	61
125	65	0.6	62	4	64
160	61	0.7	56	0	59
200	61	0.7	57	0	60
250	63	0.7	58	0	61
315	62	0.7	58	0	61
400	63	0.8	59	2	61
500	64	0.9	58	2	61
630	63	0.8	59	4	61
800	61	0.9	56	2	59
1000	59	0.9	53	0	56
1250	55	0.8	50	0	53
1600	53	0.8	49	2	51
2000	53	0.7	49	5	52
2500	51	0.8	46	5	49
3150	44	0.8	40	2	42
4000 [†]	36	0.8	31		34
5000 [†]	29	0.7	25		27

ISR = 49

FIIC = 54

NISR = 51

*Measured in general accordance with ASTM E 1007, without determination of confidence limits

[†] One-third octave band not included in FIIC calculations

This page does not constitute a complete report.



Room: Bathroom Unit 1014
Volume: 585 cu.ft. (59.5 cu.m.)
Assembly: CER_GCON25_CSU5_PLYWD19_WT457_GFB89_RC(406)_GWB16

Test Results:

Frequency (Hz)	L_p (dB)	T_{60} (sec)	L_n^* normalized to $A_0=108$ Sabins (dB)	Deficiencies (dB)	L'_n normalized to $T_0=0.5$ s (dB)
12.5 [†]	59				
16 [†]	57				
20 [†]	60				
25 [†]	66				
31.5 [†]	72				
40 [†]	70				
50 [†]	69				
63 [†]	70				
80 [†]	73	0.6	70		73
100	71	0.6	67	3	70
125	71	0.6	67	3	70
160	70	0.6	67	3	70
200	69	0.8	64	0	67
250	70	0.8	66	2	68
315	69	0.8	64	0	67
400	68	0.8	64	1	66
500	67	0.8	62	0	65
630	68	0.9	63	2	66
800	67	1.0	61	1	64
1000	62	1.0	56	0	59
1250	61	1.0	55	0	58
1600	59	0.8	54	1	57
2000	59	0.7	55	5	58
2500	56	0.7	52	5	55
3150	50	0.7	45	1	48
4000 [†]	43	0.7	39		41
5000 [†]	33	0.7	29		31

ISR = 43

FIIC = 48

NISR = 45

*Measured in general accordance with ASTM E 1007, without determination of confidence limits

[†] One-third octave band not included in FIIC calculations

This page does not constitute a complete report.



Room: Bathroom Unit 1016
Volume: 648 cu.ft. (65.9 cu.m.)
Assembly: CER_GCON25_CSU5_PLYWD19_WT457_GFB89_RC(406)_GWB(2)16

Test Results:

Frequency (Hz)	L_p (dB)	T_{60} (sec)	L_n^* normalized to $A_0=108$ Sabins (dB)	Deficiencies L'_n normalized to (dB)	L'_n normalized to $T_0=0.5$ s (dB)
12.5 [†]	50				
16 [†]	51				
20 [†]	61				
25 [†]	64				
31.5 [†]	65				
40 [†]	67				
50 [†]	69				
63 [†]	65				
80 [†]	67	0.7	64		66
100	62	0.7	59	0	61
125	66	0.6	63	0	65
160	70	0.7	67	4	69
200	67	0.9	62	0	65
250	64	0.9	59	0	62
315	68	1.0	63	0	65
400	67	0.9	62	0	64
500	67	0.9	62	1	65
630	67	0.9	62	2	64
800	65	1.1	59	0	62
1000	62	1.1	56	0	58
1250	60	0.9	55	0	58
1600	59	0.8	54	2	57
2000	60	0.8	56	7	58
2500	57	0.8	53	7	55
3150	51	0.8	47	4	49
4000 [†]	45	0.8	41		43
5000 [†]	37	0.7	33		35

ISR = 44

FIIC = 49

NISR = 47

*Measured in general accordance with ASTM E 1007, without determination of confidence limits

[†] One-third octave band not included in FIIC calculations

This page does not constitute a complete report.



Room: Bathroom Unit 1023
Volume: 648 cu.ft. (65.9 cu.m.)
Assembly: CER_GCON32_PLYWD19_WT457_GFB89_RC(406)_GWB16

Test Results:

Frequency (Hz)	L _p (dB)	T ₆₀ (sec)	L _n * normalized to A ₀ =108 Sabins (dB)	Deficiencies (dB)	L' _n normalized to T ₀ = 0.5 s (dB)
12.5 [†]	51				
16 [†]	49				
20 [†]	66				
25 [†]	67				
31.5 [†]	64				
40 [†]	69				
50 [†]	67				
63 [†]	73				
80 [†]	66	0.6	63		65
100	63	0.6	60	0	62
125	65	0.5	63	0	65
160	63	0.6	60	0	62
200	68	0.7	65	0	67
250	68	0.8	63	0	66
315	69	0.6	66	0	68
400	70	0.7	66	0	68
500	71	0.7	68	0	70
630	70	0.8	66	0	68
800	68	0.8	64	0	66
1000	66	0.8	61	0	64
1250	66	0.7	62	0	64
1600	66	0.7	62	2	64
2000	68	0.7	64	7	67
2500	66	0.7	62	8	65
3150	59	0.7	55	4	58
4000 [†]	52	0.6	49		51
5000 [†]	44	0.6	40		43

ISR = 37

FIIC = 41

NISR = 38

*Measured in general accordance with ASTM E 1007, without determination of confidence limits

[†] One-third octave band not included in FIIC calculations

This page does not constitute a complete report.



Room: Bathroom Unit 1025
Volume: 648 cu.ft. (65.9 cu.m.)
Assembly: CER_GCON32_PLYWD19_WT457_GFB89_RC(406)_GWB16

Test Results:

Frequency (Hz)	L_p (dB)	T_{60} (sec)	L_n^* normalized to $A_0=108$ Sabins (dB)	Deficiencies (dB)	L'_n normalized to $T_0=0.5$ s (dB)
12.5 [†]	48				
16 [†]	50				
20 [†]	60				
25 [†]	65				
31.5 [†]	63				
40 [†]	61				
50 [†]	66				
63 [†]	70				
80 [†]	66	0.6	63		65
100	64	0.6	61	0	64
125	70	0.7	66	0	69
160	67	0.5	65	0	67
200	66	0.5	64	0	66
250	68	0.6	64	0	67
315	68	0.6	65	0	67
400	70	0.7	66	0	69
500	69	0.8	64	0	66
630	69	0.7	65	0	68
800	69	0.7	65	0	67
1000	66	0.7	62	0	64
1250	65	0.7	61	0	64
1600	66	0.6	63	3	65
2000	67	0.6	64	7	66
2500	65	0.6	62	8	65
3150	59	0.6	56	5	58
4000 [†]	54	0.6	50		53
5000 [†]	45	0.6	42		45

ISR = 38

FIIC = 41

NISR = 38

*Measured in general accordance with ASTM E 1007, without determination of confidence limits

[†] One-third octave band not included in FIIC calculations

This page does not constitute a complete report.



Room: Bathroom Unit 1027
Volume: 720 cu.ft. (73.2 cu.m.)
Assembly: CER_GCON25_CSU5_PLYWD19_WT457_GFB89_RC(406)_GWB(2)16

Test Results:

Frequency (Hz)	L _p (dB)	T ₆₀ (sec)	L _n * normalized to A ₀ =108 Sabins (dB)	Deficiencies (dB)	L' _n normalized to T ₀ = 0.5 s (dB)
12.5 [†]	44				
16 [†]	46				
20 [†]	53				
25 [†]	56				
31.5 [†]	60				
40 [†]	63				
50 [†]	59				
63 [†]	67				
80 [†]	66	0.6	63		65
100	65	0.6	62	0	64
125	64	0.6	61	0	63
160	62	0.7	59	0	61
200	66	0.7	63	1	64
250	65	0.7	62	0	64
315	68	0.7	64	2	66
400	67	0.8	63	2	65
500	66	0.9	62	2	63
630	66	0.8	62	3	63
800	63	0.9	59	1	61
1000	61	0.9	56	0	58
1250	58	0.8	54	0	56
1600	57	0.8	53	2	55
2000	56	0.7	53	5	54
2500	53	0.8	49	4	51
3150	46	0.8	42	0	44
4000 [†]	36	0.8	32		34
5000 [†]	27	0.7	24		26

ISR = 47

FIIC = 50

NISR = 49

*Measured in general accordance with ASTM E 1007, without determination of confidence limits

[†] One-third octave band not included in FIIC calculations

This page does not constitute a complete report.



Room: Bedroom Unit 1010
Volume: 1287 cu.ft. (130.8 cu.m.)
Assembly: CPT_GCON32_PLYWD19_WT457_RC(406)_GWB16

Test Results:

Frequency (Hz)	L _p (dB)	T ₆₀ (sec)	L _n * normalized to A ₀ =108 Sabins (dB)	Deficiencies (dB)	L' _n normalized to T ₀ = 0.5 s (dB)
12.5 [†]	45				
16 [†]	65				
20 [†]	78				
25 [†]	73				
31.5 [†]	73				
40 [†]	66				
50 [†]	62				
63 [†]	58				
80 [†]	56	0.7	55		54
100	50	0.7	49	8	48
125	47	0.7	47	6	46
160	45	0.7	44	3	43
200	45	0.7	44	3	43
250	38	0.8	37	0	36
315	37	0.8	35	0	35
400	32	0.8	30	0	30
500	29	0.9	27	0	27
630	28	1.0	26	0	25
800	28	1.0	26	0	25
1000	28	1.1	25	0	25
1250	25	1.1	23	0	22
1600	23	1.0	20	0	20
2000	21	1.0	18	0	18
2500	20	1.0	17	0	17
3150	19	1.0	17	0	16
4000 [†]	19	0.9	17		17
5000 [†]	19	0.9	17		16

ISR = 70

FIIC = 71

NISR = 72

*Measured in general accordance with ASTM E 1007, without determination of confidence limits

[†] One-third octave band not included in FIIC calculations

This page does not constitute a complete report.



Room: Bedroom Unit 1012
Volume: 1287 cu.ft. (130.8 cu.m.)
Assembly: CPT_GCON32_PLYWD19_WT457_RC(406)_GWB16

Test Results:

Frequency (Hz)	L_p (dB)	T_{60} (sec)	L_n^* normalized to $A_0=108$ Sabins (dB)	Deficiencies (dB)	L'_n normalized to $T_0=0.5$ s (dB)
12.5 [†]	52				
16 [†]	66				
20 [†]	80				
25 [†]	69				
31.5 [†]	74				
40 [†]	63				
50 [†]	60				
63 [†]	54				
80 [†]	46	0.7	45		45
100	44	0.7	44	8	43
125	42	0.7	41	5	40
160	37	0.7	37	1	36
200	40	0.7	39	3	39
250	34	0.8	33	0	32
315	31	0.8	30	0	29
400	27	0.8	26	0	25
500	25	0.9	23	0	22
630	23	1.0	21	0	20
800	22	1.0	20	0	19
1000	22	1.1	19	0	19
1250	21	1.1	19	0	18
1600	21	1.0	18	0	18
2000	20	1.0	18	0	17
2500	20	1.0	17	0	17
3150	20	1.0	17	1	17
4000 [†]	19	0.9	18		17
5000 [†]	19	0.9	17		17

ISR = 76

FIIC = 76

NISR = 77

*Measured in general accordance with ASTM E 1007, without determination of confidence limits

[†] One-third octave band not included in FIIC calculations

This page does not constitute a complete report.



Room: Bedroom Unit 1014
Volume: 1287 cu.ft. (130.8 cu.m.)
Assembly: CPT_GCON32_PLYWD19_WT457_RC(406)_GWB16

Test Results:

Frequency (Hz)	L _p (dB)	T ₆₀ (sec)	L _n * normalized to A ₀ =108 Sabins (dB)	Deficiencies (dB)	L' _n normalized to T ₀ = 0.5 s (dB)
12.5 [†]	67				
16 [†]	68				
20 [†]	84				
25 [†]	69				
31.5 [†]	73				
40 [†]	69				
50 [†]	64				
63 [†]	62				
80 [†]	49	0.7	50		48
100	50	0.7	51	8	49
125	45	0.6	45	2	44
160	43	0.6	43	0	42
200	43	0.7	44	1	42
250	37	0.8	39	0	35
315	35	0.7	36	0	33
400	31	0.7	31	0	29
500	27	0.8	29	0	25
630	25	0.8	27	0	23
800	25	0.9	27	0	23
1000	25	0.9	27	0	23
1250	26	0.9	28	0	23
1600	26	0.9	28	0	23
2000	26	0.8	28	0	24
2500	26	0.8	28	2	24
3150	26	0.8	28	5	24
4000 [†]	26	0.8	27		24
5000 [†]	26	0.8	28		24

ISR = 70

FIIC = 69

NISR = 71

*Measured in general accordance with ASTM E 1007, without determination of confidence limits

[†] One-third octave band not included in FIIC calculations

This page does not constitute a complete report.



Room: Bedroom Unit 1016
Volume: 1287 cu.ft. (130.8 cu.m.)
Assembly: CPT_GCON32_PLYWD19_WT457_RC(406)_GWB(2)16

Test Results:

Frequency (Hz)	L _p (dB)	T ₆₀ (sec)	L _n * normalized to A ₀ =108 Sabins (dB)	Deficiencies (dB)	L' _n normalized to T ₀ = 0.5 s (dB)
12.5 [†]	45				
16 [†]	66				
20 [†]	80				
25 [†]	71				
31.5 [†]	70				
40 [†]	64				
50 [†]	66				
63 [†]	54				
80 [†]	50	0.7	49		48
100	46	0.7	45	6	44
125	47	0.6	47	8	46
160	44	0.6	44	5	43
200	43	0.7	43	4	42
250	39	0.8	37	0	36
315	35	0.7	34	0	33
400	32	0.8	30	0	30
500	29	0.9	27	0	27
630	25	0.9	23	0	22
800	23	1.1	20	0	20
1000	23	1.0	21	0	20
1250	23	1.0	20	0	20
1600	22	1.0	20	0	19
2000	21	0.9	19	0	18
2500	20	0.8	19	0	18
3150	20	0.9	18	0	17
4000 [†]	20	0.9	18		17
5000 [†]	20	0.9	18		17

ISR = 73

FIIC = 73

NISR = 74

*Measured in general accordance with ASTM E 1007, without determination of confidence limits

[†] One-third octave band not included in FIIC calculations

This page does not constitute a complete report.



Room: Kitchen Unit 1010
Volume: 2070 cu.ft. (210.4 cu.m.)
Assembly: VSHT_GCON32_PLYWD19_WT457_GFB89_RC(406)_GWB16

Test Results:

Frequency (Hz)	L_p (dB)	T_{60} (sec)	L_n^* normalized to $A_0=108$ Sabins (dB)	Deficiencies (dB)	L'_n normalized to $T_0=0.5$ s (dB)
12.5 [†]	68				
16 [†]	68				
20 [†]	66				
25 [†]	53				
31.5 [†]	62				
40 [†]	69				
50 [†]	72				
63 [†]	69				
80 [†]	64	0.7	65		63
100	60	0.7	61	0	58
125	62	0.8	63	0	60
160	68	0.7	69	0	67
200	69	0.8	70	1	67
250	71	0.9	71	2	68
315	67	0.9	67	0	64
400	68	0.9	68	0	65
500	68	0.8	69	2	66
630	68	0.7	69	3	66
800	66	0.9	66	1	63
1000	64	0.8	65	1	62
1250	63	0.9	64	3	61
1600	62	0.9	62	4	59
2000	61	0.8	62	7	59
2500	57	0.8	57	5	55
3150	50	0.8	50	1	48
4000 [†]	42	0.8	43		40
5000 [†]	34	0.8	35		32

ISR = 43

FIIC = 43

NISR = 45

*Measured in general accordance with ASTM E 1007, without determination of confidence limits

[†] One-third octave band not included in FIIC calculations

This page does not constitute a complete report.



Room: Kitchen Unit 1012
Volume: 2070 cu.ft. (210.4 cu.m.)
Assembly: VSHT_GCON25_CSU5_PLYWD19_WT457_GFB89_RC(406)_GWB16

Test Results:

Frequency (Hz)	L_p (dB)	T_{60} (sec)	L_n^* normalized to $A_0=108$ Sabins (dB)	Deficiencies L'_n normalized to (dB)	L'_n normalized to $T_0=0.5$ s (dB)
12.5 [†]	66				
16 [†]	58				
20 [†]	66				
25 [†]	65				
31.5 [†]	76				
40 [†]	70				
50 [†]	68				
63 [†]	60				
80 [†]	57	0.7	58		56
100	57	0.7	59	0	56
125	63	0.7	64	2	61
160	64	0.7	65	3	62
200	62	0.7	63	1	60
250	62	0.7	64	2	61
315	60	0.7	61	0	58
400	60	0.7	62	1	59
500	61	0.7	62	2	60
630	60	0.7	61	2	58
800	59	0.8	60	2	57
1000	56	0.8	57	0	54
1250	54	0.8	55	1	52
1600	52	0.8	52	1	50
2000	51	0.7	52	4	49
2500	47	0.7	48	3	46
3150	38	0.8	39	0	36
4000 [†]	28	0.8	29		26
5000 [†]	21	0.7	22		19

ISR = 51

FIIC = 50

NISR = 53

*Measured in general accordance with ASTM E 1007, without determination of confidence limits

[†] One-third octave band not included in FIIC calculations

This page does not constitute a complete report.



Room: Kitchen Unit 1014
Volume: 2070 cu.ft. (210.4 cu.m.)
Assembly: VSHT_GCON25_CSU5_PLYWD19_WT457_GFB89_RC(406)_GWB16

Test Results:

Frequency (Hz)	L _p (dB)	T ₆₀ (sec)	L _n * normalized to A ₀ =108 Sabins (dB)	Deficiencies (dB)	L' _n normalized to T ₀ = 0.5 s (dB)
12.5 [†]	72				
16 [†]	63				
20 [†]	71				
25 [†]	64				
31.5 [†]	76				
40 [†]	68				
50 [†]	68				
63 [†]	67				
80 [†]	62	0.7	64		61
100	61	0.7	62	0	60
125	67	0.7	68	5	65
160	68	0.7	69	6	67
200	64	0.7	65	2	62
250	65	0.7	66	3	63
315	64	0.7	65	2	63
400	63	0.7	65	3	62
500	62	0.7	63	2	61
630	62	0.7	63	3	60
800	59	0.8	59	0	56
1000	56	0.8	56	0	53
1250	53	0.8	54	0	51
1600	52	0.8	52	0	50
2000	51	0.7	52	3	50
2500	44	0.7	45	0	42
3150	35	0.8	36	0	33
4000 [†]	28	0.8	29		26
5000 [†]	26	0.7	28		25

ISR = 50

FIIC = 49

NISR = 51

*Measured in general accordance with ASTM E 1007, without determination of confidence limits

[†] One-third octave band not included in FIIC calculations

This page does not constitute a complete report.



Room: Kitchen Unit 1016
Volume: 2070 cu.ft. (210.4 cu.m.)
Assembly: VSHT_GCON25_CSU5_PLYWD19_WT457_GFB89_RC(406)_GWB(2)16

Test Results:

Frequency (Hz)	L _p (dB)	T ₆₀ (sec)	L _n * normalized to A ₀ =108 Sabins (dB)	Deficiencies (dB)	L' _n normalized to T ₀ = 0.5 s (dB)
12.5 [†]	57				
16 [†]	63				
20 [†]	66				
25 [†]	66				
31.5 [†]	71				
40 [†]	66				
50 [†]	69				
63 [†]	68				
80 [†]	62	0.7	63		60
100	61	0.7	62	0	59
125	63	0.7	64	0	61
160	67	0.6	69	5	66
200	68	0.7	69	5	66
250	68	0.7	69	5	66
315	65	0.7	66	2	64
400	63	0.7	65	2	62
500	63	0.7	65	3	62
630	63	0.7	64	3	61
800	59	0.7	61	1	58
1000	58	0.8	58	0	56
1250	55	0.8	55	0	53
1600	52	0.9	52	0	50
2000	51	0.8	52	2	49
2500	46	0.8	47	0	44
3150	39	0.9	39	0	36
4000 [†]	32	0.8	32		30
5000 [†]	26	0.8	26		23

ISR = 49

FIIC = 48

NISR = 51

*Measured in general accordance with ASTM E 1007, without determination of confidence limits

[†] One-third octave band not included in FIIC calculations

This page does not constitute a complete report.



Room: Kitchen Unit 1023
Volume: 2592 cu.ft. (263.4 cu.m.)
Assembly: VPLK_GCON32_PLYWD19_WT457_GFB89_RC(406)_GWB16

Test Results:

Frequency (Hz)	L_p (dB)	T_{60} (sec)	L_n^* normalized to $A_0=108$ Sabins (dB)	Deficiencies (dB)	L'_n normalized to $T_0=0.5$ s (dB)
12.5 [†]	64				
16 [†]	60				
20 [†]	59				
25 [†]	60				
31.5 [†]	63				
40 [†]	67				
50 [†]	61				
63 [†]	60				
80 [†]	52	0.7	54		50
100	53	0.7	55	0	51
125	59	0.8	61	0	57
160	58	0.6	61	0	57
200	62	0.7	64	0	61
250	60	0.6	63	0	59
315	61	0.6	64	0	60
400	63	0.6	65	0	62
500	63	0.6	66	0	62
630	63	0.6	65	0	62
800	62	0.7	64	0	60
1000	59	0.8	61	0	57
1250	58	0.8	60	0	56
1600	58	0.8	60	3	56
2000	60	0.8	62	8	58
2500	57	0.7	59	8	55
3150	49	0.8	51	3	47
4000 [†]	39	0.7	41		37
5000 [†]	30	0.7	32		29

ISR = 46

FIIC = 44

NISR = 48

*Measured in general accordance with ASTM E 1007, without determination of confidence limits

[†] One-third octave band not included in FIIC calculations

This page does not constitute a complete report.



Room: Kitchen Unit 1025
Volume: 2592 cu.ft. (263.4 cu.m.)
Assembly: VPLK_GCON32_PLYWD19_WT457_GFB89_RC(406)_GWB16

Test Results:

Frequency (Hz)	L_p (dB)	T_{60} (sec)	L_n^* normalized to $A_0=108$ Sabins (dB)	Deficiencies (dB)	L'_n normalized to $T_0=0.5$ s (dB)
12.5 [†]	59				
16 [†]	55				
20 [†]	66				
25 [†]	62				
31.5 [†]	62				
40 [†]	66				
50 [†]	63				
63 [†]	62				
80 [†]	56	0.6	59		56
100	57	0.6	59	0	56
125	62	0.7	64	0	61
160	62	0.8	63	0	59
200	60	0.7	62	0	59
250	62	0.8	63	0	60
315	63	0.8	64	0	61
400	65	0.9	66	0	62
500	65	1.0	66	1	62
630	63	0.8	65	1	61
800	62	0.9	63	0	60
1000	60	1.0	60	0	57
1250	59	1.0	60	1	56
1600	59	1.0	60	4	56
2000	60	0.9	61	8	57
2500	56	0.8	58	8	54
3150	49	0.9	50	3	47
4000 [†]	42	0.8	44		40
5000 [†]	33	0.8	35		31

ISR = 46

FIIC = 45

NISR = 49

*Measured in general accordance with ASTM E 1007, without determination of confidence limits

[†] One-third octave band not included in FIIC calculations

This page does not constitute a complete report.



Room: Kitchen Unit 1027
Volume: 1980 cu.ft. (201.2 cu.m.)
Assembly: VSHT_GCON25_CSU5_PLYWD19_WT457_GFB89_RC(406)_GWB(2)16

Test Results:

Frequency (Hz)	L _p (dB)	T ₆₀ (sec)	L _n * normalized to A ₀ =108 Sabins (dB)	Deficiencies (dB)	L' _n normalized to T ₀ = 0.5 s (dB)
12.5 [†]	49				
16 [†]	51				
20 [†]	59				
25 [†]	50				
31.5 [†]	62				
40 [†]	63				
50 [†]	59				
63 [†]	67				
80 [†]	64	0.7	65		62
100	58	0.7	59	0	56
125	60	0.7	61	0	59
160	65	0.7	66	5	64
200	61	0.7	63	2	60
250	65	0.7	66	5	64
315	62	0.7	63	2	61
400	65	0.7	66	6	64
500	64	0.7	65	6	62
630	60	0.7	61	3	58
800	56	0.8	57	0	54
1000	53	0.8	53	0	51
1250	51	0.8	51	0	48
1600	47	0.8	48	0	45
2000	45	0.7	46	0	44
2500	40	0.7	41	0	39
3150	30	0.8	31	0	28
4000 [†]	26	0.8	26		24
5000 [†]	25	0.7	26		23

ISR = 52

FIIC = 51

NISR = 53

*Measured in general accordance with ASTM E 1007, without determination of confidence limits

[†] One-third octave band not included in FIIC calculations

This page does not constitute a complete report.



Room: Living Room Unit 1010
Volume: 3312 cu.ft. (336.6 cu.m.)
Assembly: CPT_GCON32_PLYWD19_WT457_RC(406)_GWB16

Test Results:

Frequency (Hz)	L_p (dB)	T_{60} (sec)	L_n^* normalized to $A_0=108$ Sabins (dB)	Deficiencies (dB)	L'_n normalized to $T_0=0.5$ s (dB)
12.5 [†]	60				
16 [†]	70				
20 [†]	81				
25 [†]	54				
31.5 [†]	63				
40 [†]	60				
50 [†]	61				
63 [†]	63				
80 [†]	55	0.6	59		55
100	47	0.6	51	8	47
125	43	0.7	46	3	41
160	43	0.7	47	4	42
200	43	0.7	46	3	41
250	35	0.6	39	0	34
315	32	0.7	35	0	31
400	30	0.7	34	0	29
500	28	0.8	30	0	26
630	26	0.7	30	0	25
800	25	0.8	28	0	23
1000	25	0.9	27	0	22
1250	23	0.8	26	0	21
1600	23	0.8	25	0	21
2000	21	0.8	23	0	19
2500	19	0.8	22	0	17
3150	19	0.8	22	0	17
4000 [†]	19	0.8	22		17
5000 [†]	19	0.7	22		17

ISR = 73

FIIC = 69

NISR = 73

*Measured in general accordance with ASTM E 1007, without determination of confidence limits

[†] One-third octave band not included in FIIC calculations

This page does not constitute a complete report.



Room: Living Room Unit 1012
Volume: 3402 cu.ft. (345.7 cu.m.)
Assembly: CPT_GCON32_PLYWD19_WT457_RC(406)_GWB16

Test Results:

Frequency (Hz)	L_p (dB)	T_{60} (sec)	L_n^* normalized to $A_0=108$ Sabins (dB)	Deficiencies (dB)	L'_n normalized to $T_0=0.5$ s (dB)
12.5 [†]	69				
16 [†]	60				
20 [†]	76				
25 [†]	60				
31.5 [†]	68				
40 [†]	62				
50 [†]	61				
63 [†]	54				
80 [†]	49	0.6	53		48
100	44	0.6	48	6	43
125	47	0.7	50	8	45
160	38	0.7	41	0	36
200	38	0.7	41	0	36
250	31	0.6	35	0	30
315	27	0.7	31	0	26
400	25	0.7	28	0	23
500	22	0.8	25	0	20
630	21	0.7	25	0	20
800	22	0.8	25	0	20
1000	21	0.9	24	0	19
1250	21	0.8	24	0	19
1600	21	0.8	24	0	19
2000	19	0.8	22	0	17
2500	19	0.8	21	0	17
3150	19	0.8	21	0	17
4000 [†]	19	0.8	22		17
5000 [†]	19	0.7	22		18

ISR = 73

FIIC = 70

NISR = 75

*Measured in general accordance with ASTM E 1007, without determination of confidence limits

[†] One-third octave band not included in FIIC calculations

This page does not constitute a complete report.



Room: Living Room Unit 1014
Volume: 3402 cu.ft. (345.7 cu.m.)
Assembly: CPT_GCON32_PLYWD19_WT457_RC(406)_GWB16

Test Results:

Frequency (Hz)	L _p (dB)	T ₆₀ (sec)	L _n * normalized to A ₀ =108 Sabins (dB)	Deficiencies (dB)	L' _n normalized to T ₀ = 0.5 s (dB)
12.5 [†]	68				
16 [†]	58				
20 [†]	75				
25 [†]	61				
31.5 [†]	66				
40 [†]	63				
50 [†]	64				
63 [†]	57				
80 [†]	53	0.6	57		52
100	48	0.6	52	8	47
125	45	0.7	48	4	43
160	41	0.6	45	1	41
200	41	0.7	44	0	39
250	36	0.7	40	0	35
315	33	0.7	36	0	32
400	28	0.6	32	0	27
500	25	0.7	29	0	24
630	25	0.6	29	0	24
800	25	0.7	29	0	24
1000	26	0.8	29	0	24
1250	27	0.8	30	0	25
1600	27	0.8	30	0	25
2000	26	0.8	29	0	24
2500	26	0.8	29	2	24
3150	26	0.7	29	5	24
4000 [†]	26	0.8	29		24
5000 [†]	26	0.7	29		24

ISR = 72

FIIC = 68

NISR = 73

*Measured in general accordance with ASTM E 1007, without determination of confidence limits

[†] One-third octave band not included in FIIC calculations

This page does not constitute a complete report.



Room: Living Room Unit 1016
Volume: 3312 cu.ft. (336.6 cu.m.)
Assembly: CPT_GCON32_PLYWD19_WT457_RC(406)_GWB(2)16

Test Results:

Frequency (Hz)	L_p (dB)	T_{60} (sec)	L_n^* normalized to $A_0=108$ Sabins (dB)	Deficiencies (dB)	L'_n normalized to $T_0=0.5$ s (dB)
12.5 [†]	58				
16 [†]	70				
20 [†]	74				
25 [†]	57				
31.5 [†]	58				
40 [†]	56				
50 [†]	60				
63 [†]	58				
80 [†]	52	0.8	55		50
100	42	0.8	45	7	40
125	40	1.0	41	3	37
160	42	0.9	44	6	39
200	44	0.9	46	8	41
250	36	1.0	38	0	33
315	32	0.9	34	0	30
400	27	1.0	29	0	24
500	25	1.0	27	0	22
630	24	0.9	26	0	21
800	24	1.0	25	0	21
1000	25	0.9	27	0	22
1250	25	0.9	27	0	23
1600	25	0.9	27	0	22
2000	22	0.9	25	1	20
2500	20	0.9	22	1	18
3150	19	0.9	22	4	17
4000 [†]	19	0.9	21		17
5000 [†]	19	0.8	21		16

ISR = 76

FIIC = 74

NISR = 79

*Measured in general accordance with ASTM E 1007, without determination of confidence limits

[†] One-third octave band not included in FIIC calculations

This page does not constitute a complete report.



Room: Living Room Unit 1027
Volume: 2178 cu.ft. (221.3 cu.m.)
Assembly: CPT_GCON32_PLYWD19_WT457_RC(406)_GWB(2)16

Test Results:

Frequency (Hz)	L _p (dB)	T ₆₀ (sec)	L _n * normalized to A ₀ =108 Sabins (dB)	Deficiencies (dB)	L' _n normalized to T ₀ = 0.5 s (dB)
12.5 [†]	65				
16 [†]	52				
20 [†]	70				
25 [†]	57				
31.5 [†]	64				
40 [†]	63				
50 [†]	58				
63 [†]	54				
80 [†]	49	0.6	51		48
100	43	0.6	45	3	42
125	41	0.7	43	1	40
160	39	0.7	40	0	37
200	41	0.7	42	0	39
250	36	0.6	38	0	35
315	36	0.7	38	0	35
400	37	0.7	38	0	35
500	39	0.8	40	0	37
630	34	0.7	35	0	32
800	35	0.8	36	0	33
1000	36	0.9	37	0	34
1250	34	0.8	35	1	32
1600	35	0.8	36	5	33
2000	33	0.8	34	6	31
2500	29	0.8	30	5	27
3150	28	0.8	29	7	26
4000 [†]	27	0.8	28		25
5000 [†]	24	0.7	25		22

ISR = 71

FIIC = 70

NISR = 73

*Measured in general accordance with ASTM E 1007, without determination of confidence limits

[†] One-third octave band not included in FIIC calculations

This page does not constitute a complete report.



Room: Bathroom Unit 203
Volume: 688.5 cu.ft. (70 cu.m.)
Assembly: CER_GCON19_PLYWD19_WT457_GFB89_RC(406)_GWB16

Test Results:

Frequency (Hz)	L _p (dB)	T ₆₀ (sec)	L _n * normalized to A ₀ =108 Sabins (dB)	Deficiencies (dB)	L' _n normalized to T ₀ = 0.5 s (dB)
12.5 [†]	51				
16 [†]	50				
20 [†]	55				
25 [†]	59				
31.5 [†]	70				
40 [†]	71				
50 [†]	68				
63 [†]	75				
80 [†]	68	0.7	65		67
100	67	0.7	64	0	66
125	68	0.7	64	0	66
160	68	0.7	65	0	67
200	72	0.7	68	0	70
250	76	0.7	72	0	74
315	74	0.7	71	0	73
400	74	0.8	70	0	72
500	72	0.9	67	0	69
630	73	0.8	69	0	71
800	73	0.8	69	0	71
1000	72	0.9	67	0	69
1250	68	0.8	64	0	66
1600	70	0.8	65	1	68
2000	72	0.7	68	7	70
2500	70	0.7	66	8	68
3150	64	0.7	61	6	63
4000 [†]	59	0.7	56		58
5000 [†]	51	0.7	48		50

ISR = 33

FIIC = 37

NISR = 35

*Measured in general accordance with ASTM E 1007, without determination of confidence limits

[†] One-third octave band not included in FIIC calculations

This page does not constitute a complete report.



Room: Bathroom Unit 204
Volume: 504 cu.ft. (51.2 cu.m.)
Assembly: CER_RMU2_GCON19_PLYWD19_WT457_GFB89_RC(406)_GWB16

Test Results:

Frequency (Hz)	L_p (dB)	T_{60} (sec)	L_n^* normalized to $A_0=108$ Sabins (dB)	Deficiencies L'_n normalized to (dB)	L'_n normalized to $T_0=0.5$ s (dB)
12.5 [†]	69				
16 [†]	71				
20 [†]	56				
25 [†]	56				
31.5 [†]	61				
40 [†]	57				
50 [†]	51				
63 [†]	64				
80 [†]	63	0.7	58		61
100	63	0.7	59	0	62
125	56	0.7	51	0	54
160	63	0.7	58	0	61
200	67	0.7	62	0	65
250	64	0.7	59	0	62
315	67	0.7	62	0	66
400	67	0.8	62	0	65
500	68	0.9	63	0	66
630	66	0.8	61	0	64
800	66	0.8	61	0	64
1000	64	0.9	58	0	62
1250	65	0.8	60	1	63
1600	65	0.8	59	3	63
2000	66	0.7	61	8	64
2500	63	0.7	58	8	61
3150	55	0.7	51	4	54
4000 [†]	47	0.7	42		45
5000 [†]	39	0.7	35		38

ISR = 40

FIIC = 45

NISR = 42

*Measured in general accordance with ASTM E 1007, without determination of confidence limits

[†] One-third octave band not included in FIIC calculations

This page does not constitute a complete report.



Room: Bathroom Unit 205
Volume: 432 cu.ft. (43.9 cu.m.)
Assembly: CER_RMU2_GCON19_PLYWD19_WT457_GFB89_RC(406)_GWB16

Test Results:

Frequency (Hz)	L_p (dB)	T_{60} (sec)	L_n^* normalized to $A_0=108$ Sabins (dB)	Deficiencies L'_n normalized to (dB)	L'_n normalized to $T_0=0.5$ s (dB)
12.5 [†]	44				
16 [†]	48				
20 [†]	69				
25 [†]	60				
31.5 [†]	73				
40 [†]	66				
50 [†]	65				
63 [†]	66				
80 [†]	65	0.7	59		63
100	58	0.7	53	0	57
125	64	0.7	59	0	63
160	65	0.7	59	0	63
200	68	0.7	62	0	66
250	68	0.7	63	0	67
315	69	0.7	64	0	68
400	68	0.8	62	0	66
500	68	0.9	61	0	66
630	69	0.8	62	0	66
800	68	0.8	62	0	66
1000	66	0.9	59	0	63
1250	66	0.8	60	0	64
1600	65	0.8	59	2	63
2000	67	0.7	61	7	65
2500	64	0.7	59	8	63
3150	55	0.7	50	2	54
4000 [†]	48	0.7	43		47
5000 [†]	42	0.7	37		41

ISR = 39

FIIC = 44

NISR = 40

*Measured in general accordance with ASTM E 1007, without determination of confidence limits

[†] One-third octave band not included in FIIC calculations

This page does not constitute a complete report.



Room: Bathroom Unit 207
Volume: 567 cu.ft. (57.6 cu.m.)
Assembly: CER_RMU5_GCON19_PLYWD19_WT457_GFB89_RC(406)_GWB16

Test Results:

Frequency (Hz)	L_p (dB)	T_{60} (sec)	L_n^* normalized to $A_0=108$ Sabins (dB)	Deficiencies L'_n normalized to (dB)	L'_n normalized to $T_0=0.5$ s (dB)
12.5 [†]	70				
16 [†]	56				
20 [†]	66				
25 [†]	66				
31.5 [†]	75				
40 [†]	68				
50 [†]	63				
63 [†]	67				
80 [†]	65	0.7	60		63
100	61	0.7	57	0	60
125	66	0.7	61	0	64
160	71	0.7	66	0	69
200	70	0.7	66	0	69
250	72	0.7	68	2	71
315	69	0.7	65	0	68
400	71	0.8	66	1	69
500	69	0.9	64	0	67
630	71	0.8	66	3	69
800	70	0.8	65	3	68
1000	70	0.9	64	3	67
1250	69	0.8	64	6	67
1600	64	0.8	59	4	61
2000	60	0.7	56	4	59
2500	56	0.7	51	2	54
3150	49	0.7	45	0	48
4000 [†]	44	0.7	40		43
5000 [†]	40	0.7	36		39

ISR = 41

FIIC = 46

NISR = 43

*Measured in general accordance with ASTM E 1007, without determination of confidence limits

[†] One-third octave band not included in FIIC calculations

This page does not constitute a complete report.



Room: Entry Unit 203
Volume: 360 cu.ft. (36.6 cu.m.)
Assembly: SLT_GCON19_PLYWD19_WT457_GFB89_RC(406)_GWB16

Test Results:

Frequency (Hz)	L_p (dB)	T_{60} (sec)	L_n^* normalized to $A_0=108$ Sabins (dB)	Deficiencies L'_n normalized to (dB)	L'_n normalized to $T_0=0.5$ s (dB)
12.5 [†]	53				
16 [†]	50				
20 [†]	57				
25 [†]	51				
31.5 [†]	65				
40 [†]	71				
50 [†]	79				
63 [†]	77				
80 [†]	79	0.6	73		78
100	72	0.6	66	1	71
125	69	0.9	61	0	66
160	66	0.8	59	0	64
200	65	0.7	59	0	64
250	65	0.8	58	0	63
315	68	0.7	62	0	67
400	70	0.8	63	0	68
500	70	0.9	62	0	67
630	69	0.8	62	0	67
800	68	0.7	62	1	67
1000	65	0.8	58	0	63
1250	63	0.7	57	0	62
1600	65	0.8	58	4	63
2000	66	0.7	59	8	64
2500	61	0.8	55	7	59
3150	55	0.8	48	3	53
4000 [†]	48	0.8	41		46
5000 [†]	40	0.8	33		38

ISR = 40

FIIC = 47

NISR = 42

*Measured in general accordance with ASTM E 1007, without determination of confidence limits

[†] One-third octave band not included in FIIC calculations

This page does not constitute a complete report.



Room: Entry Unit 204
Volume: 540 cu.ft. (54.9 cu.m.)
Assembly: SLT_RMU2_GCON19_PLYWD19_WT457_GFB89_RC(406)_GWB16

Test Results:

Frequency (Hz)	L_p (dB)	T_{60} (sec)	L_n^* normalized to $A_0=108$ Sabins (dB)	Deficiencies (dB)	L'_n normalized to $T_0=0.5$ s (dB)
12.5 [†]	49				
16 [†]	49				
20 [†]	54				
25 [†]	55				
31.5 [†]	58				
40 [†]	61				
50 [†]	70				
63 [†]	70				
80 [†]	62	0.6	58		61
100	63	0.6	59	0	62
125	68	0.9	62	1	65
160	68	0.8	63	2	66
200	65	0.7	60	0	63
250	68	0.8	63	2	66
315	67	0.7	62	1	65
400	66	0.8	61	1	64
500	65	0.9	60	1	63
630	63	0.8	58	0	61
800	61	0.7	56	0	59
1000	59	0.8	54	0	57
1250	58	0.7	53	0	57
1600	58	0.8	52	2	56
2000	60	0.7	55	8	58
2500	56	0.8	51	7	54
3150	49	0.8	44	3	47
4000 [†]	43	0.8	38		41
5000 [†]	37	0.8	32		35

ISR = 46

FIIC = 51

NISR = 48

*Measured in general accordance with ASTM E 1007, without determination of confidence limits

[†] One-third octave band not included in FIIC calculations

This page does not constitute a complete report.



Room: Entry Unit 207
Volume: 288 cu.ft. (29.3 cu.m.)
Assembly: SLT_RMU5_GCON19_PLYWD19_WT457_GFB89_RC(406)_GWB16

Test Results:

Frequency (Hz)	L_p (dB)	T_{60} (sec)	L_n^* normalized to $A_0=108$ Sabins (dB)	Deficiencies (dB)	L'_n normalized to $T_0=0.5$ s (dB)
12.5 [†]	47				
16 [†]	51				
20 [†]	52				
25 [†]	58				
31.5 [†]	63				
40 [†]	68				
50 [†]	64				
63 [†]	61				
80 [†]	63	0.6	57		63
100	57	0.6	50	0	56
125	64	0.9	55	0	61
160	65	0.8	58	3	63
200	66	0.7	59	4	65
250	64	0.8	57	2	62
315	64	0.7	56	1	62
400	64	0.8	56	2	62
500	63	0.9	54	1	60
630	62	0.8	54	2	60
800	59	0.7	52	1	58
1000	58	0.8	50	0	56
1250	56	0.7	48	1	54
1600	54	0.8	46	2	52
2000	54	0.7	46	5	52
2500	48	0.8	40	2	46
3150	42	0.8	34	0	40
4000 [†]	36	0.8	28		34
5000 [†]	31	0.8	23		29

ISR = 49

FIIC = 57

NISR = 51

*Measured in general accordance with ASTM E 1007, without determination of confidence limits

[†] One-third octave band not included in FIIC calculations

This page does not constitute a complete report.



Room: Kitchen Unit 203
Volume: 1620 cu.ft. (164.6 cu.m.)
Assembly: VSHT_GCON19_PLYWD19_WT457_GFB89_RC(406)_GWB16

Test Results:

Frequency (Hz)	L _p (dB)	T ₆₀ (sec)	L _n * normalized to A ₀ =108 Sabins (dB)	Deficiencies (dB)	L' _n normalized to T ₀ = 0.5 s (dB)
12.5 [†]	47				
16 [†]	58				
20 [†]	63				
25 [†]	62				
31.5 [†]	73				
40 [†]	70				
50 [†]	71				
63 [†]	68				
80 [†]	67	0.5	69		67
100	65	0.5	66	0	65
125	72	0.6	73	3	71
160	71	0.6	72	2	70
200	71	0.8	70	0	69
250	73	0.8	72	2	71
315	71	1.1	70	0	68
400	70	1.3	67	0	66
500	70	0.8	69	1	68
630	69	0.8	69	2	67
800	68	0.7	68	2	67
1000	65	0.7	65	0	63
1250	64	0.8	63	1	61
1600	62	0.8	61	2	60
2000	61	0.8	61	5	59
2500	58	0.7	58	5	56
3150	51	0.8	50	0	49
4000 [†]	44	0.8	43		42
5000 [†]	37	0.8	36		35

ISR = 42

FIIC = 42

NISR = 44

*Measured in general accordance with ASTM E 1007, without determination of confidence limits

[†] One-third octave band not included in FIIC calculations

This page does not constitute a complete report.



Room: Kitchen Unit 204
Volume: 1350 cu.ft. (137.2 cu.m.)
Assembly: VPLK_RMU2_GCON19_PLYWD19_WT457_GFB89_RC(406)_GWB16

Test Results:

Frequency (Hz)	L _p (dB)	T ₆₀ (sec)	L _n * normalized to A ₀ =108 Sabins (dB)	Deficiencies (dB)	L' _n normalized to T ₀ = 0.5 s (dB)
12.5 [†]	47				
16 [†]	51				
20 [†]	57				
25 [†]	65				
31.5 [†]	69				
40 [†]	72				
50 [†]	71				
63 [†]	66				
80 [†]	61	0.5	62		61
100	62	0.5	63	1	62
125	67	0.6	67	5	66
160	66	0.6	66	4	65
200	67	0.8	65	3	65
250	67	0.8	66	4	65
315	67	1.1	64	2	63
400	66	1.3	63	2	62
500	62	0.8	61	1	60
630	62	0.8	61	2	60
800	58	0.7	58	0	57
1000	54	0.7	54	0	53
1250	51	0.8	49	0	49
1600	47	0.8	45	0	45
2000	41	0.8	40	0	39
2500	36	0.7	35	0	34
3150	32	0.8	31	0	30
4000 [†]	31	0.8	29		28
5000 [†]	28	0.8	27		26

ISR = 49

FIIC = 50

NISR = 51

*Measured in general accordance with ASTM E 1007, without determination of confidence limits

[†] One-third octave band not included in FIIC calculations

This page does not constitute a complete report.



Room: Kitchen Unit 205
Volume: 2457 cu.ft. (249.7 cu.m.)
Assembly: SLT_RMU2_GCON19_PLYWD19_WT457_GFB89_RC(406)_GWB16

Test Results:

Frequency (Hz)	L_p (dB)	T_{60} (sec)	L_n^* normalized to $A_0=108$ Sabins (dB)	Deficiencies (dB)	L'_n normalized to $T_0=0.5$ s (dB)
12.5 [†]	49				
16 [†]	62				
20 [†]	73				
25 [†]	69				
31.5 [†]	66				
40 [†]	75				
50 [†]	70				
63 [†]	64				
80 [†]	64	0.6	67		64
100	56	0.6	58	0	55
125	57	0.9	58	0	54
160	59	0.8	61	0	57
200	65	0.7	67	1	64
250	63	0.8	64	0	61
315	65	0.7	67	1	64
400	66	0.8	68	3	64
500	63	0.9	64	0	60
630	64	0.8	66	3	62
800	61	0.7	63	1	59
1000	60	0.8	61	0	58
1250	58	0.7	60	2	56
1600	57	0.8	58	3	55
2000	56	0.7	58	6	55
2500	51	0.8	52	3	49
3150	44	0.8	45	0	42
4000 [†]	38	0.8	39		36
5000 [†]	31	0.8	33		29

ISR = 48

FIIC = 46

NISR = 50

*Measured in general accordance with ASTM E 1007, without determination of confidence limits

[†] One-third octave band not included in FIIC calculations

This page does not constitute a complete report.



Room: Kitchen Unit 206
Volume: 1350 cu.ft. (137.2 cu.m.)
Assembly: VPLK_RMU2_GCON19_PLYWD19_WT457_GFB89_RC(406)_GWB16

Test Results:

Frequency (Hz)	L_p (dB)	T_{60} (sec)	L_n^* normalized to $A_0=108$ Sabins (dB)	Deficiencies (dB)	L'_n normalized to $T_0=0.5$ s (dB)
12.5 [†]	49				
16 [†]	53				
20 [†]	63				
25 [†]	60				
31.5 [†]	64				
40 [†]	70				
50 [†]	71				
63 [†]	66				
80 [†]	73	0.5	74		73
100	70	0.5	71	4	70
125	71	0.6	71	4	71
160	69	0.6	70	3	69
200	74	0.8	73	6	72
250	73	0.8	72	5	71
315	72	1.1	70	3	69
400	69	1.3	66	0	65
500	69	0.8	67	2	67
630	63	0.8	62	0	61
800	57	0.7	57	0	56
1000	54	0.7	54	0	53
1250	52	0.8	51	0	50
1600	48	0.8	46	0	46
2000	43	0.8	41	0	40
2500	40	0.7	39	0	38
3150	40	0.8	38	0	38
4000 [†]	38	0.8	36		35
5000 [†]	33	0.8	32		31

ISR = 44

FIIC = 45

NISR = 46

*Measured in general accordance with ASTM E 1007, without determination of confidence limits

[†] One-third octave band not included in FIIC calculations

This page does not constitute a complete report.



Room: Kitchen Unit 207
Volume: 2457 cu.ft. (249.7 cu.m.)
Assembly: SLT_RMU5_GCON19_PLYWD19_WT457_GFB89_RC(406)_GWB16

Test Results:

Frequency (Hz)	L _p (dB)	T ₆₀ (sec)	L _n * normalized to A ₀ =108 Sabins (dB)	Deficiencies (dB)	L' _n normalized to T ₀ = 0.5 s (dB)
12.5 [†]	48				
16 [†]	56				
20 [†]	73				
25 [†]	65				
31.5 [†]	72				
40 [†]	78				
50 [†]	73				
63 [†]	66				
80 [†]	58	0.6	61		58
100	57	0.6	60	0	56
125	61	0.9	62	0	59
160	61	0.8	62	0	59
200	64	0.7	66	2	62
250	62	0.8	64	0	60
315	64	0.7	66	2	63
400	64	0.8	65	2	61
500	63	0.9	64	2	61
630	62	0.8	63	2	60
800	61	0.7	63	3	59
1000	59	0.8	60	1	57
1250	57	0.7	59	3	56
1600	55	0.8	57	4	53
2000	54	0.7	56	6	53
2500	50	0.8	51	4	48
3150	44	0.8	45	1	42
4000 [†]	37	0.8	38		35
5000 [†]	31	0.8	33		29

ISR = 49

FIIC = 48

NISR = 51

*Measured in general accordance with ASTM E 1007, without determination of confidence limits

[†] One-third octave band not included in FIIC calculations

This page does not constitute a complete report.



Room: Living Room Unit 203
Volume: 3240 cu.ft. (329.3 cu.m.)
Assembly: CPT_GCON19_PLYWD19_WT457_RC(406)_GWB16

Test Results:

Frequency (Hz)	L _p (dB)	T ₆₀ (sec)	L _n * normalized to A ₀ =108 Sabins (dB)	Deficiencies (dB)	L' _n normalized to T ₀ = 0.5 s (dB)
12.5 [†]	60				
16 [†]	65				
20 [†]	82				
25 [†]	68				
31.5 [†]	66				
40 [†]	62				
50 [†]	66				
63 [†]	69				
80 [†]	63	0.8	65		61
100	52	0.8	55	8	50
125	46	0.9	48	1	44
160	44	0.7	47	0	43
200	42	0.8	44	0	40
250	37	0.8	40	0	35
315	34	0.7	38	0	33
400	33	0.7	37	0	32
500	31	0.6	35	0	30
630	28	0.6	32	0	28
800	27	0.7	31	0	26
1000	26	0.7	29	0	25
1250	26	0.8	29	0	24
1600	26	0.8	29	0	24
2000	27	0.9	29	0	24
2500	28	1.0	29	0	25
3150	28	1.0	29	2	24
4000 [†]	27	1.0	29		24
5000 [†]	27	0.9	30		25

ISR = 68

FIIC = 65

NISR = 70

*Measured in general accordance with ASTM E 1007, without determination of confidence limits

[†] One-third octave band not included in FIIC calculations

This page does not constitute a complete report.



Room: Living Room Unit 204
Volume: 1872 cu.ft. (190.2 cu.m.)
Assembly: CPT_GCON19_PLYWD19_WT457_RC(406)_GWB16

Test Results:

Frequency (Hz)	L _p (dB)	T ₆₀ (sec)	L _n * normalized to A ₀ =108 Sabins (dB)	Deficiencies (dB)	L' _n normalized to T ₀ = 0.5 s (dB)
12.5 [†]	53				
16 [†]	75				
20 [†]	73				
25 [†]	66				
31.5 [†]	66				
40 [†]	59				
50 [†]	58				
63 [†]	53				
80 [†]	53	0.8	54		51
100	44	0.8	44	6	42
125	44	0.9	44	6	41
160	41	0.7	41	3	39
200	42	0.8	43	5	40
250	33	0.8	34	0	31
315	32	0.7	32	0	30
400	31	0.7	32	0	29
500	27	0.6	29	0	26
630	28	0.6	29	0	27
800	26	0.7	26	0	24
1000	26	0.7	27	0	25
1250	26	0.8	26	0	24
1600	26	0.8	26	0	24
2000	25	0.9	25	1	23
2500	25	1.0	25	4	22
3150	26	1.0	25	7	23
4000 [†]	26	1.0	26		23
5000 [†]	27	0.9	27		24

ISR = 74

FIIC = 74

NISR = 76

*Measured in general accordance with ASTM E 1007, without determination of confidence limits

[†] One-third octave band not included in FIIC calculations

This page does not constitute a complete report.



Room: NNR* - Unit CV101 Bedroom to Unit CV102 Bedroom - NNIC 51
Assembly: GCON19_PLYWD19_WT457_GFB89_RC(203)_GWB16

Test Results:

Frequency (Hz)	NR (dB)	T ₆₀ (sec)	NNR* Normalized to T ₆₀ = 0.5 sec (dB)	Deficiencies (dB)
12.5 [†]	2			
16 [†]	2			
20 [†]	2			
25 [†]	15			
31.5 [†]	16			
40 [†]	23			
50 [†]	26			
63 [†]	22			
80 [†]	18	0.7	19	
100	32	0.6	32	0
125	40	0.5	40	0
160	33	0.5	33	5
200	37	0.6	37	4
250	42	0.6	42	2
315	42	0.6	42	5
400	48	0.8	50	0
500	49	0.8	52	0
630	48	0.8	50	2
800	48	0.7	50	3
1000	46	0.6	47	7
1250	51	0.7	52	3
1600	55	0.7	56	0
2000	59	0.7	61	0
2500	60	0.7	62	0
3150	64	0.7	66	0
4000	69	0.7	71	0
5000 [†]	73	0.7	75	

Field Normalized Noise Isolation Class (NNIC) = 51

*Measured in general accordance with ASTM E 336, without determination of flanking paths or confidence limits

[†] One-third octave band not included in NNIC calculations

This page does not constitute a complete report.



Room: NNR* - Unit 2105 Bathroom to Unit 2205 Bathroom - NNIC 57
Assembly: CER_GCON19_PLYWD19_WT457_GFB152.4_RC(406)_GWB16

Test Results:

Frequency (Hz)	NR (dB)	T ₆₀ (sec)	NNR* Normalized to T ₆₀ = 0.5 sec (dB)	Deficiencies (dB)
12.5 [†]	1			
16 [†]	6			
20 [†]	17			
25 [†]	25			
31.5 [†]	27			
40 [†]	28			
50 [†]	25			
63 [†]	16			
80 [†]	33	0.5	33	
100	36	0.5	36	0
125	43	0.5	43	0
160	42	0.5	42	2
200	45	0.7	46	1
250	45	0.8	47	3
315	49	0.7	51	2
400	50	0.8	52	4
500	50	0.8	52	5
630	53	0.8	55	3
800	54	0.8	56	3
1000	56	0.8	58	2
1250	59	0.8	61	0
1600	62	0.8	64	0
2000	62	0.7	63	0
2500	64	0.7	65	0
3150	70	0.7	71	0
4000	76	0.7	78	0
5000 [†]	80	0.7	81	

Field Normalized Noise Isolation Class (NNIC) = 57

*Measured in general accordance with ASTM E 336, without determination of flanking paths or confidence limits

[†] One-third octave band not included in NNIC calculations

This page does not constitute a complete report.



Room: NNR* - Unit 2105 Bedroom to Unit 2205 Bedroom - NNIC 55
Assembly: CPT_GCON19_PLYWD19_WT457_GFB152.4_RC(406)_GWB16

Test Results:

Frequency (Hz)	NR (dB)	T ₆₀ (sec)	NNR* Normalized to T ₆₀ = 0.5 sec (dB)	Deficiencies (dB)
12.5 [†]	0			
16 [†]	2			
20 [†]	6			
25 [†]	11			
31.5 [†]	17			
40 [†]	17			
50 [†]	13			
63 [†]	14			
80 [†]	18	0.6	19	
100	32	0.6	33	0
125	31	0.9	33	6
160	42	0.6	43	0
200	38	0.7	39	6
250	44	0.6	45	3
315	46	0.5	46	5
400	48	0.6	48	6
500	53	0.6	53	2
630	56	0.8	58	0
800	59	0.7	60	0
1000	62	0.7	63	0
1250	65	0.8	67	0
1600	66	0.7	67	0
2000	61	0.6	62	0
2500	60	0.6	61	0
3150	69	0.7	70	0
4000	75	0.7	76	0
5000 [†]	76	0.6	77	

Field Normalized Noise Isolation Class (NNIC) = 55

*Measured in general accordance with ASTM E 336, without determination of flanking paths or confidence limits

[†] One-third octave band not included in NNIC calculations

This page does not constitute a complete report.



Room: NNR* - Unit 2105 Kitchen to Unit 2205 Kitchen - NNIC 56
Assembly: WD_GCON19_PLYWD19_WT457_GFB152.4_RC(406)_GWB16

Test Results:

Frequency (Hz)	NR (dB)	T ₆₀ (sec)	NNR* Normalized to T ₆₀ = 0.5 sec (dB)	Deficiencies (dB)
12.5 [†]	2			
16 [†]	3			
20 [†]	11			
25 [†]	22			
31.5 [†]	30			
40 [†]	23			
50 [†]	22			
63 [†]	22			
80 [†]	26	0.6	26	
100	35	0.6	36	0
125	39	0.5	39	1
160	41	0.5	41	2
200	44	0.6	45	1
250	44	0.6	45	4
315	48	0.6	49	3
400	49	0.5	49	6
500	50	0.6	51	5
630	54	0.4	53	4
800	56	0.4	55	3
1000	59	0.5	59	0
1250	63	0.5	63	0
1600	65	0.6	65	0
2000	64	0.7	65	0
2500	65	0.7	66	0
3150	71	0.8	73	0
4000	76	0.8	78	0
5000 [†]	77	0.7	78	

Field Normalized Noise Isolation Class (NNIC) = 56

*Measured in general accordance with ASTM E 336, without determination of flanking paths or confidence limits

[†] One-third octave band not included in NNIC calculations

This page does not constitute a complete report.



Room: NNR* - Unit 2105 Living Room to Unit 2205 Living Room - NNIC 53
Assembly: CPT_GCON19_PLYWD19_WT457_GFB152.4_RC(406)_GWB16

Test Results:

Frequency (Hz)	NR (dB)	T ₆₀ (sec)	NNR* Normalized to T ₆₀ = 0.5 sec (dB)	Deficiencies (dB)
12.5 [†]	0			
16 [†]	3			
20 [†]	2			
25 [†]	10			
31.5 [†]	18			
40 [†]	25			
50 [†]	20			
63 [†]	16			
80 [†]	19	0.6	20	
100	25	0.6	26	0
125	29	0.6	29	8
160	39	0.7	40	0
200	40	0.7	41	2
250	43	0.7	44	2
315	48	0.8	50	0
400	50	0.6	51	1
500	52	0.6	52	1
630	55	0.6	56	0
800	59	0.6	60	0
1000	63	0.6	63	0
1250	65	0.6	66	0
1600	66	0.6	67	0
2000	63	0.6	64	0
2500	62	0.6	62	0
3150	69	0.7	70	0
4000	75	0.7	77	0
5000 [†]	77	0.6	78	

Field Normalized Noise Isolation Class (NNIC) = 53

*Measured in general accordance with ASTM E 336, without determination of flanking paths or confidence limits

[†] One-third octave band not included in NNIC calculations

This page does not constitute a complete report.



Room: NNR* - Unit 1010 Bathroom to Unit 1020 Bathroom - NNIC 53
Assembly: CER_GCON32_PLYWD19_WT457_GFB89_RC(406)_GWB16

Test Results:

Frequency (Hz)	NR (dB)	T ₆₀ (sec)	NNR* Normalized to T ₆₀ = 0.5 sec (dB)	Deficiencies (dB)
12.5 [†]	11			
16 [†]	25			
20 [†]	26			
25 [†]	19			
31.5 [†]	21			
40 [†]	25			
50 [†]	26			
63 [†]	30			
80 [†]	31	0.6	31	
100	39	0.6	40	0
125	42	0.6	42	0
160	34	0.6	35	5
200	37	0.6	38	5
250	42	0.8	44	2
315	41	0.9	44	5
400	45	1.1	48	4
500	46	1.0	49	4
630	49	0.9	52	2
800	51	1.0	54	1
1000	55	1.1	58	0
1250	57	0.9	60	0
1600	59	0.9	62	0
2000	60	0.7	62	0
2500	65	0.7	66	0
3150	72	0.7	74	0
4000	79	0.7	81	0
5000 [†]	82	0.7	84	

Field Normalized Noise Isolation Class (NNIC) = 53

*Measured in general accordance with ASTM E 336, without determination of flanking paths or confidence limits

[†] One-third octave band not included in NNIC calculations

This page does not constitute a complete report.



Room: NNR* - Unit 1012 Bathroom to Unit 1022 Bathroom - NNIC 58
Assembly: CER_GCON25_CSU5_PLYWD19_WT457_GFB89_RC(406)_GWB16

Test Results:

Frequency (Hz)	NR (dB)	T ₆₀ (sec)	NNR* Normalized to T ₆₀ = 0.5 sec (dB)	Deficiencies (dB)
12.5 [†]	5			
16 [†]	13			
20 [†]	15			
25 [†]	20			
31.5 [†]	28			
40 [†]	34			
50 [†]	38			
63 [†]	35			
80 [†]	31	0.6	32	
100	36	0.6	36	0
125	34	0.6	35	7
160	48	0.6	48	0
200	47	0.6	48	0
250	47	0.8	49	2
315	47	0.9	50	4
400	48	1.1	51	6
500	50	1.0	53	5
630	53	0.9	55	4
800	55	1.0	58	2
1000	60	1.1	63	0
1250	63	0.9	65	0
1600	66	0.9	69	0
2000	65	0.7	67	0
2500	70	0.7	72	0
3150	73	0.7	74	0
4000	76	0.7	78	0
5000 [†]	77	0.7	79	

Field Normalized Noise Isolation Class (NNIC) = 58

*Measured in general accordance with ASTM E 336, without determination of flanking paths or confidence limits

[†] One-third octave band not included in NNIC calculations

This page does not constitute a complete report.



Room: NNR* - Unit 1014 Bathroom to Unit 1024 Bathroom - NNIC 55
Assembly: CER_GCON25_CSU5_PLYWD19_WT457_GFB89_RC(406)_GWB16

Test Results:

Frequency (Hz)	NR (dB)	T ₆₀ (sec)	NNR* Normalized to T ₆₀ = 0.5 sec (dB)	Deficiencies (dB)
12.5 [†]	1			
16 [†]	12			
20 [†]	14			
25 [†]	22			
31.5 [†]	19			
40 [†]	25			
50 [†]	30			
63 [†]	31			
80 [†]	29	0.6	30	
100	26	0.6	27	0
125	37	0.6	38	1
160	41	0.6	42	0
200	41	0.8	43	2
250	43	0.8	45	3
315	44	0.8	46	5
400	46	0.8	48	6
500	46	0.8	48	7
630	49	0.9	51	5
800	52	1.0	55	2
1000	56	1.0	59	0
1250	60	1.0	63	0
1600	63	0.8	65	0
2000	63	0.7	64	0
2500	67	0.7	69	0
3150	72	0.7	73	0
4000	77	0.7	78	0
5000 [†]	79	0.7	80	

Field Normalized Noise Isolation Class (NNIC) = 55

*Measured in general accordance with ASTM E 336, without determination of flanking paths or confidence limits

[†] One-third octave band not included in NNIC calculations

This page does not constitute a complete report.



Room: NNR* - Unit 1016 Bathroom to Unit 1026 Bathroom - NNIC 57
Assembly: CER_GCON25_CSU5_PLYWD19_WT457_GFB89_RC(406)_GWB(2)16

Test Results:

Frequency (Hz)	NR (dB)	T ₆₀ (sec)	NNR* Normalized to T ₆₀ = 0.5 sec (dB)	Deficiencies (dB)
12.5 [†]				
16 [†]				
20 [†]	15			
25 [†]	21			
31.5 [†]	24			
40 [†]	29			
50 [†]	33			
63 [†]	20			
80 [†]	28	0.7	29	
100	31	0.7	33	0
125	40	0.6	40	1
160	38	0.7	40	4
200	45	0.9	48	0
250	45	0.9	48	2
315	45	1.0	48	5
400	49	0.9	52	4
500	49	0.9	51	6
630	52	0.9	55	3
800	54	1.1	58	1
1000	58	1.1	62	0
1250	62	0.9	65	0
1600	65	0.8	67	0
2000	64	0.8	66	0
2500	68	0.8	70	0
3150	75	0.8	77	0
4000	82	0.8	84	0
5000 [†]	85	0.7	86	

Field Normalized Noise Isolation Class (NNIC) = 57

*Measured in general accordance with ASTM E 336, without determination of flanking paths or confidence limits

[†] One-third octave band not included in NNIC calculations

This page does not constitute a complete report.



Room: NNR* - Unit 1023 Bathroom to Unit 1033 Bathroom - NNIC 55
Assembly: CER_GCON32_PLYWD19_WT457_GFB89_RC(406)_GWB16

Test Results:

Frequency (Hz)	NR (dB)	T ₆₀ (sec)	NNR* Normalized to T ₆₀ = 0.5 sec (dB)	Deficiencies (dB)
12.5 [†]	8			
16 [†]	3			
20 [†]	14			
25 [†]	24			
31.5 [†]	29			
40 [†]	28			
50 [†]	27			
63 [†]	33			
80 [†]	32	0.6	33	
100	34	0.6	34	0
125	38	0.5	38	1
160	37	0.6	37	5
200	44	0.7	46	0
250	44	0.8	46	2
315	44	0.6	44	7
400	47	0.7	49	5
500	47	0.7	48	7
630	51	0.8	53	3
800	55	0.8	57	0
1000	59	0.8	61	0
1250	62	0.7	64	0
1600	65	0.7	67	0
2000	65	0.7	67	0
2500	68	0.7	69	0
3150	74	0.7	76	0
4000	79	0.6	80	0
5000 [†]	81	0.6	82	

Field Normalized Noise Isolation Class (NNIC) = 55

*Measured in general accordance with ASTM E 336, without determination of flanking paths or confidence limits

[†] One-third octave band not included in NNIC calculations

This page does not constitute a complete report.



Room: NNR* - Unit 1025 Bathroom to Unit 1035 Bathroom - NNIC 50
Assembly: CER_GCON32_PLYWD19_WT457_GFB89_RC(406)_GWB16

Test Results:

Frequency (Hz)	NR (dB)	T ₆₀ (sec)	NNR* Normalized to T ₆₀ = 0.5 sec (dB)	Deficiencies (dB)
12.5 [†]	7			
16 [†]	5			
20 [†]	19			
25 [†]	29			
31.5 [†]	40			
40 [†]	38			
50 [†]	38			
63 [†]	32			
80 [†]	29	0.6	29	
100	30	0.6	30	0
125	25	0.7	26	8
160	36	0.5	36	1
200	45	0.5	45	0
250	45	0.6	45	0
315	43	0.6	44	2
400	45	0.7	47	2
500	48	0.8	50	0
630	51	0.7	52	0
800	54	0.7	55	0
1000	60	0.7	61	0
1250	64	0.7	65	0
1600	65	0.6	66	0
2000	64	0.6	65	0
2500	68	0.6	69	0
3150	77	0.6	77	0
4000	83	0.6	83	0
5000 [†]	85	0.6	85	

Field Normalized Noise Isolation Class (NNIC) = 50

*Measured in general accordance with ASTM E 336, without determination of flanking paths or confidence limits

[†] One-third octave band not included in NNIC calculations

This page does not constitute a complete report.



Room: NNR* - Unit 1027 Bathroom to Unit 1037 Bathroom - NNIC 58
Assembly: CER_GCON25_CSU5_PLYWD19_WT457_GFB89_RC(406)_GWB(2)16

Test Results:

Frequency (Hz)	NR (dB)	T ₆₀ (sec)	NNR* Normalized to T ₆₀ = 0.5 sec (dB)	Deficiencies (dB)
12.5 [†]	17			
16 [†]	23			
20 [†]	22			
25 [†]	26			
31.5 [†]	29			
40 [†]	33			
50 [†]	34			
63 [†]	26			
80 [†]	33	0.6	34	
100	32	0.6	32	0
125	44	0.6	45	0
160	45	0.7	47	0
200	40	0.7	41	7
250	44	0.7	45	6
315	47	0.7	49	5
400	48	0.8	50	7
500	52	0.9	54	4
630	55	0.8	57	2
800	59	0.9	61	0
1000	63	0.9	65	0
1250	67	0.8	69	0
1600	69	0.8	71	0
2000	69	0.7	70	0
2500	73	0.8	75	0
3150	79	0.8	81	0
4000	83	0.8	85	0
5000 [†]	84	0.7	85	

Field Normalized Noise Isolation Class (NNIC) = 58

*Measured in general accordance with ASTM E 336, without determination of flanking paths or confidence limits

[†] One-third octave band not included in NNIC calculations

This page does not constitute a complete report.



Room: NNR* - Unit 1010 Kitchen to Unit 1020 Kitchen - NNIC 55
Assembly: VSHT_GCON32_PLYWD19_WT457_GFB89_RC(406)_GWB16

Test Results:

Frequency (Hz)	NR (dB)	T ₆₀ (sec)	NNR* Normalized to T ₆₀ = 0.5 sec (dB)	Deficiencies (dB)
12.5 [†]				
16 [†]	2			
20 [†]	10			
25 [†]	25			
31.5 [†]	20			
40 [†]	22			
50 [†]	23			
63 [†]	25			
80 [†]	22	0.7	24	
100	25	0.7	27	0
125	36	0.8	38	1
160	40	0.7	42	0
200	37	0.8	39	6
250	41	0.9	43	5
315	47	0.9	49	2
400	49	0.9	52	2
500	49	0.8	51	4
630	52	0.7	54	2
800	54	0.9	56	1
1000	56	0.8	58	0
1250	59	0.9	61	0
1600	61	0.9	64	0
2000	61	0.8	63	0
2500	65	0.8	67	0
3150	69	0.8	71	0
4000	73	0.8	75	0
5000 [†]	75	0.8	77	

Field Normalized Noise Isolation Class (NNIC) = 55

*Measured in general accordance with ASTM E 336, without determination of flanking paths or confidence limits

[†] One-third octave band not included in NNIC calculations

This page does not constitute a complete report.



Room: NNR* - Unit 1012 Kitchen to Unit 1022 Kitchen - NNIC 59
Assembly: VSHT_GCON25_CSU5_PLYWD19_WT457_GFB89_RC(406)_GWB16

Test Results:

Frequency (Hz)	NR (dB)	T ₆₀ (sec)	NNR* Normalized to T ₆₀ = 0.5 sec (dB)	Deficiencies (dB)
12.5 [†]	8			
16 [†]	9			
20 [†]	8			
25 [†]	17			
31.5 [†]	17			
40 [†]	27			
50 [†]	33			
63 [†]	31			
80 [†]	27	0.7	29	
100	38	0.7	39	0
125	37	0.8	39	4
160	38	0.7	40	6
200	44	0.8	46	3
250	47	0.9	50	2
315	48	0.9	50	5
400	52	0.9	54	4
500	53	0.8	55	4
630	57	0.7	58	2
800	56	0.9	59	2
1000	61	0.8	63	0
1250	63	0.9	66	0
1600	61	0.9	63	0
2000	61	0.8	63	0
2500	65	0.8	67	0
3150	65	0.8	67	0
4000	69	0.8	71	0
5000 [†]	70	0.8	72	

Field Normalized Noise Isolation Class (NNIC) = 59

*Measured in general accordance with ASTM E 336, without determination of flanking paths or confidence limits

[†] One-third octave band not included in NNIC calculations

This page does not constitute a complete report.



Room: NNR* - Unit 1014 Kitchen to Unit 1024 Kitchen - NNIC 57
Assembly: VSHT_GCON25_CSU5_PLYWD19_WT457_GFB89_RC(406)_GWB16

Test Results:

Frequency (Hz)	NR (dB)	T ₆₀ (sec)	NNR* Normalized to T ₆₀ = 0.5 sec (dB)	Deficiencies (dB)
12.5 [†]	32			
16 [†]	22			
20 [†]	21			
25 [†]	17			
31.5 [†]	18			
40 [†]	20			
50 [†]	24			
63 [†]	26			
80 [†]	23	0.8	25	
100	29	0.8	31	0
125	36	0.8	38	3
160	39	0.9	41	3
200	41	0.9	44	3
250	43	1.0	46	4
315	47	0.8	49	4
400	50	0.9	52	4
500	51	0.9	54	3
630	56	1.0	59	0
800	57	0.9	59	0
1000	60	0.9	63	0
1250	60	0.9	63	0
1600	56	1.0	59	2
2000	59	0.9	61	0
2500	64	0.8	66	0
3150	65	0.9	67	0
4000	70	0.8	72	0
5000 [†]	72	0.8	74	

Field Normalized Noise Isolation Class (NNIC) = 57

*Measured in general accordance with ASTM E 336, without determination of flanking paths or confidence limits

[†] One-third octave band not included in NNIC calculations

This page does not constitute a complete report.



Room: NNR* - Unit 1016 Kitchen to Unit 1026 Kitchen - NNIC 55
Assembly: VSHT_GCON25_CSU5_PLYWD19_WT457_GFB89_RC(406)_GWB(2)16

Test Results:

Frequency (Hz)	NR (dB)	T ₆₀ (sec)	NNR* Normalized to T ₆₀ = 0.5 sec (dB)	Deficiencies (dB)
12.5 [†]	2			
16 [†]	11			
20 [†]	19			
25 [†]	23			
31.5 [†]	21			
40 [†]	27			
50 [†]	22			
63 [†]	24			
80 [†]	25	0.7	27	
100	33	0.7	34	0
125	29	0.7	31	8
160	37	0.6	38	4
200	40	0.7	41	4
250	39	0.7	40	8
315	46	0.7	48	3
400	51	0.7	52	2
500	53	0.7	55	0
630	56	0.7	57	0
800	57	0.7	58	0
1000	59	0.8	61	0
1250	61	0.8	63	0
1600	62	0.9	65	0
2000	63	0.8	65	0
2500	68	0.8	70	0
3150	72	0.9	75	0
4000	75	0.8	77	0
5000 [†]	76	0.8	78	

Field Normalized Noise Isolation Class (NNIC) = 55

*Measured in general accordance with ASTM E 336, without determination of flanking paths or confidence limits

[†] One-third octave band not included in NNIC calculations

This page does not constitute a complete report.



Room: NNR* - Unit 1023 Kitchen to Unit 1033 Kitchen - NNIC 57
Assembly: VPLK_GCON32_PLYWD19_WT457_GFB89_RC(406)_GWB16

Test Results:

Frequency (Hz)	NR (dB)	T ₆₀ (sec)	NNR* Normalized to T ₆₀ = 0.5 sec (dB)	Deficiencies (dB)
12.5 [†]	21			
16 [†]	6			
20 [†]	5			
25 [†]	11			
31.5 [†]	26			
40 [†]	22			
50 [†]	15			
63 [†]	27			
80 [†]	33	0.7	35	
100	33	0.7	34	0
125	35	0.8	37	4
160	43	0.6	44	0
200	44	0.7	46	1
250	47	0.6	48	2
315	48	0.6	49	4
400	50	0.6	50	6
500	50	0.6	51	6
630	52	0.6	53	5
800	56	0.7	57	2
1000	60	0.8	62	0
1250	59	0.8	61	0
1600	58	0.8	60	1
2000	60	0.8	62	0
2500	66	0.7	67	0
3150	70	0.8	72	0
4000	74	0.7	75	0
5000 [†]	76	0.7	77	

Field Normalized Noise Isolation Class (NNIC) = 57

*Measured in general accordance with ASTM E 336, without determination of flanking paths or confidence limits

[†] One-third octave band not included in NNIC calculations

This page does not constitute a complete report.



Room: NNR* - Unit 1025 Kitchen to Unit 1035 Kitchen - NNIC 56
Assembly: VPLK_GCON32_PLYWD19_WT457_GFB89_RC(406)_GWB16

Test Results:

Frequency (Hz)	NR (dB)	T ₆₀ (sec)	NNR* Normalized to T ₆₀ = 0.5 sec (dB)	Deficiencies (dB)
12.5 [†]	3			
16 [†]	3			
20 [†]	6			
25 [†]	11			
31.5 [†]	20			
40 [†]	21			
50 [†]	25			
63 [†]	27			
80 [†]	33	0.6	33	
100	38	0.6	38	0
125	36	0.7	37	3
160	42	0.8	44	0
200	47	0.7	48	0
250	43	0.8	45	4
315	50	0.8	52	0
400	48	0.9	50	5
500	49	1.0	52	4
630	50	0.8	52	5
800	54	0.9	57	1
1000	55	1.0	58	1
1250	54	1.0	57	3
1600	53	1.0	56	4
2000	57	0.9	60	0
2500	63	0.8	65	0
3150	65	0.9	68	0
4000	71	0.8	73	0
5000 [†]	73	0.8	75	

Field Normalized Noise Isolation Class (NNIC) = 56

*Measured in general accordance with ASTM E 336, without determination of flanking paths or confidence limits

[†] One-third octave band not included in NNIC calculations

This page does not constitute a complete report.



Room: NNR* - Unit 1027 Kitchen to Unit 1037 Kitchen - NNIC 56
Assembly: VSHT_GCON25_CSU5_PLYWD19_WT457_GFB89_RC(406)_GWB(2)16

Test Results:

Frequency (Hz)	NR (dB)	T ₆₀ (sec)	NNR* Normalized to T ₆₀ = 0.5 sec (dB)	Deficiencies (dB)
12.5 [†]	2			
16 [†]	3			
20 [†]	9			
25 [†]	18			
31.5 [†]	21			
40 [†]	17			
50 [†]	20			
63 [†]	28			
80 [†]	26	0.7	27	
100	32	0.7	33	0
125	36	0.7	38	2
160	38	0.7	40	3
200	44	0.7	45	1
250	46	0.7	48	1
315	50	0.7	51	1
400	53	0.7	54	1
500	50	0.7	52	4
630	53	0.7	55	2
800	56	0.8	58	0
1000	57	0.8	59	0
1250	56	0.8	58	2
1600	55	0.8	57	3
2000	57	0.7	58	2
2500	60	0.7	62	0
3150	60	0.8	62	0
4000	64	0.8	66	0
5000 [†]	64	0.7	66	

Field Normalized Noise Isolation Class (NNIC) = 56

*Measured in general accordance with ASTM E 336, without determination of flanking paths or confidence limits

[†] One-third octave band not included in NNIC calculations

This page does not constitute a complete report.



Room: NNR* - Unit 1010 Living Room to Unit 1020 Living Room - NNIC 55
Assembly: CPT_GCON32_PLYWD19_WT457_RC(406)_GWB16

Test Results:

Frequency (Hz)	NR (dB)	T ₆₀ (sec)	NNR* Normalized to T ₆₀ = 0.5 sec (dB)	Deficiencies (dB)
12.5 [†]				
16 [†]				
20 [†]	4			
25 [†]	20			
31.5 [†]	14			
40 [†]	19			
50 [†]	20			
63 [†]	15			
80 [†]	18	0.9	21	
100	26	0.9	29	0
125	33	0.9	36	3
160	37	0.8	39	3
200	37	1.1	40	5
250	40	1.0	43	5
315	44	0.9	47	4
400	48	0.8	50	4
500	50	0.8	52	3
630	56	0.9	58	0
800	58	0.9	60	0
1000	61	0.9	63	0
1250	61	0.9	64	0
1600	60	1.0	63	0
2000	62	1.0	65	0
2500	67	0.9	69	0
3150	68	0.9	71	0
4000	73	0.9	76	0
5000 [†]	74	0.9	77	

Field Normalized Noise Isolation Class (NNIC) = 55

*Measured in general accordance with ASTM E 336, without determination of flanking paths or confidence limits

[†] One-third octave band not included in NNIC calculations

This page does not constitute a complete report.



Room: NNR* - Unit 1012 Living Room to Unit 1022 Living Room - NNIC 59
Assembly: CPT_GCON32_PLYWD19_WT457_RC(406)_GWB16

Test Results:

Frequency (Hz)	NR (dB)	T ₆₀ (sec)	NNR* Normalized to T ₆₀ = 0.5 sec (dB)	Deficiencies (dB)
12.5 [†]	0			
16 [†]	1			
20 [†]	14			
25 [†]	21			
31.5 [†]	24			
40 [†]	15			
50 [†]	24			
63 [†]	23			
80 [†]	30	0.9	33	
100	31	0.9	34	0
125	35	0.9	37	6
160	41	0.8	43	3
200	43	1.1	46	3
250	47	1.0	50	2
315	51	0.9	54	1
400	53	0.8	55	3
500	54	0.8	56	3
630	56	0.9	58	2
800	56	0.9	59	2
1000	59	0.9	62	0
1250	63	0.9	65	0
1600	61	1.0	64	0
2000	63	1.0	66	0
2500	67	0.9	70	0
3150	68	0.9	70	0
4000	71	0.9	73	0
5000 [†]	71	0.9	74	

Field Normalized Noise Isolation Class (NNIC) = 59

*Measured in general accordance with ASTM E 336, without determination of flanking paths or confidence limits

[†] One-third octave band not included in NNIC calculations

This page does not constitute a complete report.



Room: NNR* - Unit 1014 Living Room to Unit 1024 Living Room - NNIC 55
Assembly: CPT_GCON32_PLYWD19_WT457_RC(406)_GWB16

Test Results:

Frequency (Hz)	NR (dB)	T ₆₀ (sec)	NNR* Normalized to T ₆₀ = 0.5 sec (dB)	Deficiencies (dB)
12.5 [†]				
16 [†]	7			
20 [†]	15			
25 [†]	21			
31.5 [†]	28			
40 [†]	29			
50 [†]	20			
63 [†]	12			
80 [†]	25	0.6	26	
100	28	0.6	29	0
125	29	0.7	31	8
160	41	0.6	41	1
200	40	0.7	41	4
250	41	0.7	42	6
315	46	0.7	48	3
400	50	0.6	51	3
500	53	0.7	54	1
630	55	0.6	56	0
800	58	0.7	60	0
1000	60	0.8	62	0
1250	59	0.8	61	0
1600	55	0.8	57	2
2000	59	0.8	61	0
2500	63	0.8	65	0
3150	64	0.7	65	0
4000	69	0.8	71	0
5000 [†]	72	0.7	73	

Field Normalized Noise Isolation Class (NNIC) = 55

*Measured in general accordance with ASTM E 336, without determination of flanking paths or confidence limits

[†] One-third octave band not included in NNIC calculations

This page does not constitute a complete report.



Room: NNR* - Unit 1016 Living Room to Unit 1026 Living Room - NNIC 54
Assembly: CPT_GCON32_PLYWD19_WT457_RC(406)_GWB(2)16

Test Results:

Frequency (Hz)	NR (dB)	T ₆₀ (sec)	NNR* Normalized to T ₆₀ = 0.5 sec (dB)	Deficiencies (dB)
12.5 [†]	9			
16 [†]	8			
20 [†]	9			
25 [†]	20			
31.5 [†]	25			
40 [†]	25			
50 [†]	11			
63 [†]	17			
80 [†]	23	0.6	24	
100	21	0.6	21	0
125	31	0.7	33	5
160	34	0.7	36	5
200	37	0.7	39	5
250	40	0.6	41	6
315	42	0.7	43	7
400	50	0.7	51	2
500	52	0.8	54	0
630	52	0.7	53	2
800	54	0.8	56	0
1000	61	0.9	64	0
1250	62	0.8	64	0
1600	60	0.8	62	0
2000	63	0.8	65	0
2500	67	0.8	69	0
3150	70	0.8	72	0
4000	74	0.8	76	0
5000 [†]	76	0.7	77	

Field Normalized Noise Isolation Class (NNIC) = 54

*Measured in general accordance with ASTM E 336, without determination of flanking paths or confidence limits

[†] One-third octave band not included in NNIC calculations

This page does not constitute a complete report.



Room: NNR* - Unit 1027 Living Room to Unit 1037 Living Room - NNIC 59
Assembly: CPT_GCON32_PLYWD19_WT457_RC(406)_GWB(2)16

Test Results:

Frequency (Hz)	NR (dB)	T ₆₀ (sec)	NNR* Normalized to T ₆₀ = 0.5 sec (dB)	Deficiencies (dB)
12.5 [†]	14			
16 [†]	8			
20 [†]	13			
25 [†]	21			
31.5 [†]	31			
40 [†]	28			
50 [†]	26			
63 [†]	22			
80 [†]	22	0.6	23	
100	21	0.6	21	0
125	38	0.7	39	4
160	45	0.7	47	0
200	48	0.7	49	0
250	45	0.6	46	6
315	50	0.7	51	4
400	54	0.7	55	3
500	53	0.8	55	4
630	55	0.7	57	3
800	56	0.8	58	3
1000	58	0.9	61	1
1250	59	0.8	61	2
1600	59	0.8	61	2
2000	62	0.8	64	0
2500	67	0.8	69	0
3150	70	0.8	72	0
4000	75	0.8	77	0
5000 [†]	76	0.7	77	

Field Normalized Noise Isolation Class (NNIC) = 59

*Measured in general accordance with ASTM E 336, without determination of flanking paths or confidence limits

[†] One-third octave band not included in NNIC calculations

This page does not constitute a complete report.



Room: NNR* - Unit 203 Bathroom to Unit 303 Bathroom - NNIC 53
Assembly: CER_GCON19_PLYWD19_WT457_GFB89_RC(406)_GWB16

Test Results:

Frequency (Hz)	NR (dB)	T ₆₀ (sec)	NNR* Normalized to T ₆₀ = 0.5 sec (dB)	Deficiencies (dB)
12.5 [†]				
16 [†]				
20 [†]	17			
25 [†]	30			
31.5 [†]	28			
40 [†]	24			
50 [†]	21			
63 [†]	17			
80 [†]	24	0.5	24	
100	31	0.5	31	0
125	29	0.5	29	8
160	40	0.5	40	0
200	37	0.6	38	5
250	44	0.7	45	1
315	44	0.7	46	3
400	45	0.8	47	5
500	45	0.8	47	6
630	49	0.8	51	3
800	52	1.0	55	0
1000	55	1.1	58	0
1250	59	0.9	61	0
1600	59	0.8	61	0
2000	60	0.7	62	0
2500	63	0.7	65	0
3150	66	0.7	68	0
4000	69	0.7	71	0
5000 [†]	69	0.7	70	

Field Normalized Noise Isolation Class (NNIC) = 53

*Measured in general accordance with ASTM E 336, without determination of flanking paths or confidence limits

[†] One-third octave band not included in NNIC calculations

This page does not constitute a complete report.



Room: NNR* - Unit 204 Bathroom to Unit 304 Bathroom - NNIC 57
Assembly: CER_RMU2_GCON19_PLYWD19_WT457_GFB89_RC(406)_GWB16

Test Results:

Frequency (Hz)	NR (dB)	T ₆₀ (sec)	NNR* Normalized to T ₆₀ = 0.5 sec (dB)	Deficiencies (dB)
12.5 [†]				
16 [†]	12			
20 [†]	22			
25 [†]	28			
31.5 [†]	37			
40 [†]	32			
50 [†]	31			
63 [†]	30			
80 [†]	22	0.6	23	
100	40	0.6	41	0
125	39	0.4	38	3
160	38	0.5	38	6
200	43	0.5	43	4
250	49	0.7	50	0
315	54	0.6	55	0
400	49	0.6	49	7
500	50	0.5	50	7
630	55	0.6	55	3
800	56	0.9	59	0
1000	60	0.6	60	0
1250	63	0.7	65	0
1600	64	0.6	65	0
2000	64	0.6	65	0
2500	67	0.6	68	0
3150	69	0.6	70	0
4000	72	0.6	72	0
5000 [†]	70	0.5	70	

Field Normalized Noise Isolation Class (NNIC) = 57

*Measured in general accordance with ASTM E 336, without determination of flanking paths or confidence limits

[†] One-third octave band not included in NNIC calculations

This page does not constitute a complete report.



Room: NNR* - Unit 205 Bathroom to Unit 305 Bathroom - NNIC 59
Assembly: CER_RMU2_GCON19_PLYWD19_WT457_GFB89_RC(406)_GWB16

Test Results:

Frequency (Hz)	NR (dB)	T ₆₀ (sec)	NNR* Normalized to T ₆₀ = 0.5 sec (dB)	Deficiencies (dB)
12.5 [†]	16			
16 [†]	20			
20 [†]	27			
25 [†]	28			
31.5 [†]	34			
40 [†]	31			
50 [†]	29			
63 [†]	18			
80 [†]	20	0.5	20	
100	42	0.5	42	0
125	39	0.5	39	4
160	46	0.6	46	0
200	40	0.8	42	7
250	49	0.8	51	1
315	49	0.6	50	5
400	51	0.8	53	5
500	54	0.9	57	2
630	56	0.9	58	2
800	58	0.9	61	0
1000	60	0.9	63	0
1250	62	0.8	64	0
1600	63	0.8	65	0
2000	64	0.7	66	0
2500	66	0.7	68	0
3150	69	0.7	70	0
4000	71	0.7	73	0
5000 [†]	70	0.6	71	

Field Normalized Noise Isolation Class (NNIC) = 59

*Measured in general accordance with ASTM E 336, without determination of flanking paths or confidence limits

[†] One-third octave band not included in NNIC calculations

This page does not constitute a complete report.



Room: NNR* - Unit 207 Bathroom to Unit 307 Bathroom - NNIC 58
Assembly: CER_RMU5_GCON19_PLYWD19_WT457_GFB89_RC(406)_GWB16

Test Results:

Frequency (Hz)	NR (dB)	T ₆₀ (sec)	NNR* Normalized to T ₆₀ = 0.5 sec (dB)	Deficiencies (dB)
12.5 [†]				
16 [†]				
20 [†]	7			
25 [†]	22			
31.5 [†]	27			
40 [†]	32			
50 [†]	33			
63 [†]	23			
80 [†]	21	0.6	22	
100	37	0.6	38	0
125	39	0.6	40	2
160	45	0.6	46	0
200	46	0.6	47	1
250	47	0.6	47	4
315	48	0.7	49	5
400	52	0.8	54	3
500	53	0.8	55	3
630	54	0.9	57	2
800	56	0.9	59	1
1000	58	0.9	61	0
1250	60	0.8	62	0
1600	61	0.8	63	0
2000	60	0.7	61	1
2500	63	0.7	65	0
3150	64	0.7	66	0
4000	69	0.7	70	0
5000 [†]	69	0.7	71	

Field Normalized Noise Isolation Class (NNIC) = 58

*Measured in general accordance with ASTM E 336, without determination of flanking paths or confidence limits

[†] One-third octave band not included in NNIC calculations

This page does not constitute a complete report.



Room: NNR* - Unit 203 Kitchen to Unit 303 Kitchen - NNIC 55
Assembly: VSHT_GCON19_PLYWD19_WT457_GFB89_RC(406)_GWB16

Test Results:

Frequency (Hz)	NR (dB)	T ₆₀ (sec)	NNR* Normalized to T ₆₀ = 0.5 sec (dB)	Deficiencies (dB)
12.5 [†]				
16 [†]	9			
20 [†]	25			
25 [†]	29			
31.5 [†]	27			
40 [†]	23			
50 [†]	16			
63 [†]	21			
80 [†]	25	0.5	25	
100	26	0.5	26	0
125	30	0.7	32	7
160	39	0.7	40	2
200	43	0.6	43	2
250	48	0.7	49	0
315	47	0.6	48	3
400	51	0.5	51	3
500	53	0.5	53	2
630	54	0.5	54	2
800	55	0.6	55	2
1000	57	0.6	58	0
1250	58	0.6	59	0
1600	60	0.6	61	0
2000	61	0.6	61	0
2500	64	0.5	64	0
3150	68	0.6	69	0
4000	71	0.6	72	0
5000 [†]	72	0.6	73	

Field Normalized Noise Isolation Class (NNIC) = 55

*Measured in general accordance with ASTM E 336, without determination of flanking paths or confidence limits

[†] One-third octave band not included in NNIC calculations

This page does not constitute a complete report.



Room: NNR - Unit 204 Kitchen to Unit 304 Kitchen - NNIC 55
Assembly: VPLK_RMU2_GCON19_PLYWD19_WT457_GFB89_RC(406)_GWB16

Test Results:

Frequency (Hz)	NR (dB)	T ₆₀ (sec)	NNR* Normalized to T ₆₀ = 0.5 sec (dB)	Deficiencies (dB)
12.5 [†]	7			
16 [†]	11			
20 [†]	22			
25 [†]	28			
31.5 [†]	33			
40 [†]	33			
50 [†]	30			
63 [†]	21			
80 [†]	33	0.5	33	
100	46	0.5	46	0
125	37	0.5	37	2
160	44	0.4	43	0
200	41	0.6	42	3
250	39	0.6	40	8
315	47	0.8	49	2
400	50	0.7	51	3
500	51	0.5	51	4
630	53	0.6	54	2
800	55	0.7	56	1
1000	58	0.7	60	0
1250	60	0.7	61	0
1600	60	0.7	62	0
2000	63	0.6	64	0
2500	65	0.7	66	0
3150	63	0.7	64	0
4000	66	0.7	68	0
5000 [†]	65	0.7	67	

Field Normalized Noise Isolation Class (NNIC) = 55

*Measured in general accordance with ASTM E 336, without determination of flanking paths or confidence limits

[†] One-third octave band not included in NNIC calculations

This page does not constitute a complete report.



Room: NNR* - Unit 205 Kitchen to Unit 305 Kitchen - NNIC 58
Assembly: SLT_RMU2_GCON19_PLYWD19_WT457_GFB89_RC(406)_GWB16

Test Results:

Frequency (Hz)	NR (dB)	T ₆₀ (sec)	NNR* Normalized to T ₆₀ = 0.5 sec (dB)	Deficiencies (dB)
12.5 [†]	4			
16 [†]	11			
20 [†]	24			
25 [†]	27			
31.5 [†]	33			
40 [†]	30			
50 [†]	24			
63 [†]	25			
80 [†]	31	0.6	31	
100	38	0.6	39	0
125	41	0.7	43	0
160	39	0.7	41	4
200	45	0.9	47	1
250	41	0.8	43	8
315	47	0.6	48	6
400	50	0.7	51	6
500	56	0.7	57	1
630	57	0.7	59	0
800	60	0.7	61	0
1000	60	0.8	62	0
1250	59	0.7	61	1
1600	61	0.8	63	0
2000	63	0.8	65	0
2500	66	0.7	67	0
3150	63	0.8	65	0
4000	66	0.8	68	0
5000 [†]	65	0.7	66	

Field Normalized Noise Isolation Class (NNIC) = 58

*Measured in general accordance with ASTM E 336, without determination of flanking paths or confidence limits

[†] One-third octave band not included in NNIC calculations

This page does not constitute a complete report.



Room: NNR* - Unit 206 Kitchen to Unit 306 Kitchen - NNIC 50
Assembly: VPLK_RMU2_GCON19_PLYWD19_WT457_GFB89_RC(406)_GWB16

Test Results:

Frequency (Hz)	NR (dB)	T ₆₀ (sec)	NNR* Normalized to T ₆₀ = 0.5 sec (dB)	Deficiencies (dB)
12.5 [†]	3			
16 [†]	16			
20 [†]	24			
25 [†]	31			
31.5 [†]	32			
40 [†]	22			
50 [†]	18			
63 [†]	19			
80 [†]	25	0.5	25	
100	34	0.5	34	0
125	28	0.5	28	6
160	41	0.6	42	0
200	38	0.6	39	1
250	37	0.6	38	5
315	41	0.7	42	4
400	43	0.6	44	5
500	43	0.8	45	5
630	49	0.6	50	1
800	49	0.6	50	2
1000	53	0.7	55	0
1250	55	0.7	56	0
1600	57	0.7	59	0
2000	58	0.7	60	0
2500	62	0.7	64	0
3150	59	0.8	61	0
4000	62	0.8	64	0
5000 [†]	57	0.7	58	

Field Normalized Noise Isolation Class (NNIC) = 50

*Measured in general accordance with ASTM E 336, without determination of flanking paths or confidence limits

[†] One-third octave band not included in NNIC calculations

This page does not constitute a complete report.



Room: NNR* - Unit 207 Kitchen to Unit 307 Kitchen - NNIC 62
Assembly: SLT_RMU5_GCON19_PLYWD19_WT457_GFB89_RC(406)_GWB16

Test Results:

Frequency (Hz)	NR (dB)	T ₆₀ (sec)	NNR* Normalized to T ₆₀ = 0.5 sec (dB)	Deficiencies (dB)
12.5 [†]				
16 [†]	4			
20 [†]	17			
25 [†]	24			
31.5 [†]	28			
40 [†]	27			
50 [†]	23			
63 [†]	27			
80 [†]	41	0.5	41	
100	37	0.5	37	0
125	44	0.7	45	1
160	44	0.6	44	5
200	45	0.7	47	5
250	48	0.9	51	4
315	50	0.8	52	6
400	56	0.8	58	3
500	61	0.7	62	0
630	60	0.8	62	1
800	62	0.8	64	0
1000	63	0.7	64	1
1250	65	0.7	66	0
1600	63	0.8	65	1
2000	63	0.7	65	1
2500	65	0.8	67	0
3150	63	0.8	65	1
4000	66	0.8	68	0
5000 [†]	65	0.7	66	

Field Normalized Noise Isolation Class (NNIC) = 62

*Measured in general accordance with ASTM E 336, without determination of flanking paths or confidence limits

[†] One-third octave band not included in NNIC calculations

This page does not constitute a complete report.



Room: NNR* - Unit 203 Living Room to Unit 303 Living Room - NNIC 55
Assembly: CPT_GCON19_PLYWD19_WT457_RC(406)_GWB16

Test Results:

Frequency (Hz)	NR (dB)	T ₆₀ (sec)	NNR* Normalized to T ₆₀ = 0.5 sec (dB)	Deficiencies (dB)
12.5 [†]				
16 [†]	3			
20 [†]	13			
25 [†]	17			
31.5 [†]	22			
40 [†]	25			
50 [†]	20			
63 [†]	10			
80 [†]	12	0.7	13	
100	35	0.7	36	0
125	35	0.9	37	2
160	33	0.6	34	8
200	37	0.6	38	7
250	40	0.8	42	6
315	46	0.7	48	3
400	53	0.8	55	0
500	53	1.3	57	0
630	57	0.8	59	0
800	61	0.8	63	0
1000	63	0.8	65	0
1250	63	0.8	65	0
1600	63	0.8	65	0
2000	62	0.7	64	0
2500	65	0.7	66	0
3150	63	0.7	64	0
4000	65	0.7	66	0
5000 [†]	64	0.7	65	

Field Normalized Noise Isolation Class (NNIC) = 55

*Measured in general accordance with ASTM E 336, without determination of flanking paths or confidence limits

[†] One-third octave band not included in NNIC calculations

This page does not constitute a complete report.



Room: NNR* - Unit 204 Living Room to Unit 304 Living Room - NNIC 58
Assembly: CPT_GCON19_PLYWD19_WT457_RC(406)_GWB16

Test Results:

Frequency (Hz)	NR (dB)	T ₆₀ (sec)	NNR* Normalized to T ₆₀ = 0.5 sec (dB)	Deficiencies (dB)
12.5 [†]				
16 [†]	5			
20 [†]	13			
25 [†]	18			
31.5 [†]	24			
40 [†]	26			
50 [†]	28			
63 [†]	27			
80 [†]	22	0.7	24	
100	30	0.7	31	0
125	38	0.6	38	4
160	39	0.7	40	5
200	42	0.7	43	5
250	45	0.7	47	4
315	48	0.7	49	5
400	49	0.8	51	6
500	54	0.9	56	2
630	57	0.6	58	1
800	59	0.7	61	0
1000	63	0.7	65	0
1250	61	0.7	63	0
1600	62	0.8	64	0
2000	62	0.7	63	0
2500	64	0.7	66	0
3150	62	0.8	64	0
4000	65	0.7	66	0
5000 [†]	65	0.7	66	

Field Normalized Noise Isolation Class (NNIC) = 58

*Measured in general accordance with ASTM E 336, without determination of flanking paths or confidence limits

[†] One-third octave band not included in NNIC calculations

This page does not constitute a complete report.